

SKYSTREAM^{3.7}
OWNER'S MANUAL 60 HZ
(NORTH AMERICA) EDITION

Installation
Operation
Maintenance

CE FC

MADE IN THE USA © 2012 Southwest Windpower, Inc.
All Rights Reserved

Southwest Windpower

Congratulations on your purchase and welcome to our family!

Dear Skystream 3.7® Owner,

Thank you for your purchase of Skystream. You have just selected the most technologically advanced, cost-effective renewable energy appliance available for a home or small business. We congratulate you on your choice and are confident you will experience years of dependable service.

Before going any further, please complete and return the enclosed Warranty Registration Card. **The conditions of your warranty are dependent upon the proper installation of Skystream.** Furthermore, this will assure you of being kept up-to-date with the latest developments from Southwest Windpower. These include new options, performance tips, updated software to maximize output and user notices. It is important to know that we do not sell or distribute your information to any third party. We understand your privacy is important.

If you have any questions or comments, we would like to hear from you. Please call during working hours (Monday-Friday 8:00 am to 5:00 pm - Mountain Time Zone - Daylight Savings not observed). Our phone number is **928-779-9463, toll free 866-807-9463.**

Again, welcome to our family and thank you for investing in the future of wind energy with Skystream.

Sincerely,

Southwest Windpower

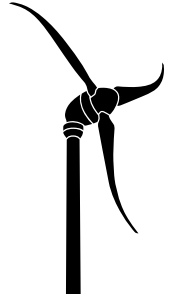

Enter the serial and model number below

Serial Number _____

Model Number _____

Skystream Owner's Manual
3-CMLT-1054
Revision: L

IMPORTANT SAFETY INSTRUCTIONS

READ THESE INSTRUCTIONS IN THEIR ENTIRETY BEFORE INSTALLING OR OPERATING.



PROFESSIONAL INSTALLATION: Southwest Windpower strongly recommends Skystream be installed by trained professionals.

- 1) **SAVE THESE INSTRUCTIONS.** This manual contains important instructions for Skystream that must be followed during installation and maintenance.
- 2) Read, understand and respect all warnings.
- 3) Turn Skystream "OFF" if "GROWLING" or unusual noise or operation is observed. Contact Southwest Windpower Technical service.
- 4) Install Skystream on a calm day - no wind at ground level.
- 5) Install Skystream in accordance with National Electric Code (NEC) and local building codes.
- 6) Always obtain a building permit before construction.
- 7) A minimum of 2 adults are required to safely lift or move Skystream. Use proper equipment such as hydraulic hoists to lift Skystream.
- 8) Always wear appropriate protective personal equipment such as closed toe work shoes, hard hat, work gloves, and safety glasses when working on or installing Skystream.
- 9) Turn Skystream "OFF" if ice accumulates on blades to avoid possible injury resulting from ice flying off blades.
- 10) This wind generator complies with international safety standards, and therefore the design or its installation must never be compromised.
 - a. Do not open the inverter cover; doing so without factory authorization will void the warranty.
 - b. Apply the proper torque to all fasteners.
 - c. Torque field wire connections to Skystream to 2.3-2.5 N-m. Refer to Electrical Connections section of this manual (Section 2-1-2).
 - d. Install only on a Professional Engineer (PE) certified tower.
 - e. Do not paint the blades.
- 11) Use only proper grounding techniques as established by the NEC.
- 12) Properly complete the warranty registration card; failure to complete and return the card may affect your warranty.
- 13) Skystream must be installed in accordance with this manual and local and national building codes. Failure to comply with the manual and local codes will affect and possibly void your warranty.
- 14) Skystream uses high voltage and is potentially dangerous. Be sure to use all safety precautions at all times.

In this manual



IMPORTANT:
Please take note



TIP: Helpful information
to ease the installation



Professional installation
highly recommended



Warning: Risk of injury or
death - proceed with extreme
caution

Radio (RF) Interference (USA)

Skystream 3.7 has been tested and found to comply with the limits for a class B digital device, pursuant to Part 15 of the FCC Rules (US Federal Communications Commission). These limits are designed to provide reasonable protection against harmful interference in a residential installation. Skystream generates, uses and can radiate radio frequency energy and, if not installed and used in accordance with the instructions, may cause harmful interference to radio communications. However, there is no guarantee that interference will not occur in a particular installation. If Skystream does cause harmful interference to radio or television reception, which can be determined by turning the Skystream on and off, you are encouraged to correct the interference by one or more of the following measures:

- Reorient or relocate the Skyview Interface Module or Remote Display.
- Increase the separation between Skystream and Skyview Interface Module or Remote Display.

Radio (RF) Interference (EU)

Complies to European Standards EN 61000-6-3 (2007), EN 61000-6-2 (2005), EN 61000-3-2 (1995), EN 61000-3-3 (2000).

TABLE OF CONTENTS

IMPORTANT SAFETY INSTRUCTIONS _____	4
RADIO INTERFERENCE _____	5
SKYSTREAM 3.7® WARRANTY _____	7
SKYSTREAM 3.7® SPECIFICATIONS _____	8-9
EUROPEAN GRID STANDARDS _____	10
PRIOR TO INSTALLATION _____	11
INTENDED USE _____	11
UNINTENDED USE _____	11
INSTALLATION PERSONNEL _____	12
TYPICAL SKYSTREAM INSTALLATION _____	13
SITING – FINDING THE BEST LOCATION FOR SKYSTREAM _____	14
LOCAL REQUIREMENTS _____	14
INSTALLATION _____	15
INTRODUCTION _____	15
WIRE SIZING _____	15
GROUNDING _____	16
UTILITY PANEL CONNECTIONS _____	16
ELECTRICAL CONNECTIONS TO SKYSTREAM _____	17-18
INSTALLING SKYSTREAM ON A TOWER _____	19
BOLTING SKYSTREAM TO THE TOWER _____	20-22
BLADES, NOSECONE AND ANTENNA ASSEMBLY _____	23-24
OPERATION _____	25
MANUAL OPERATION OF SKYSTREAM _____	25
MAINTENANCE _____	25-26
SERVICE _____	26
TROUBLESHOOTING _____	26
EMERGENCY SHUTDOWN _____	26
KEY OPERATING CHARACTERISTICS _____	27
DISPOSAL OF SKYSTREAM _____	28
FREQUENTLY ASKED QUESTIONS _____	29

APPENDICES

Appendix A: Electrical Diagrams

1 Grid Connection Option A _____	3
2 Grid Connection Option B _____	4
3 Grid Connection Option C _____	5
4 Grid Connection Option D _____	6
5 Skystream Block Diagram _____	7

Appendix B: Tower Grounding

1 Introduction _____	4
2 Grounding Techniques _____	4-9

Appendix C: Lightning Protection

1 Introduction _____	4
2 Lightning Protection Data _____	4-9

Appendix D: Compliance/Certification Documents

1 UL (US & Canada) _____	2-3
2 CE (Europe) _____	4

Skystream 3.7[®] Limited 5-Year Warranty

WIND TURBINE WARRANTY AGREEMENT

Hardware Warranty

Southwest Windpower, Inc., (“Southwest Windpower”) will repair or replace free of charge any part or parts of the Southwest Windpower Skystream 3.7[®] wind generator determined by Southwest Windpower to be defective in materials and/or workmanship under normal authorized use consistent with product instructions for a period of five years from the date the original purchaser (“Customer”) receives the wind generator (“Start Date”). This warranty extends only to the original purchaser. The Customer’s sole and exclusive remedy and the entire liability of Southwest Windpower, its suppliers and affiliates under the warranty is, at Southwest Windpower’s option, either (i) to replace the wind generator with new or reconditioned wind generator, (ii) to correct the reported problem, or (iii) to refund the purchase price of the wind generator. Repaired or replaced products are warranted for the remainder of the original warranty period.

Restrictions

Problems with the wind generator products can be due to improper use, maintenance, non-Southwest Windpower additions or modifications or other problems not due to defects in Southwest Windpower’s workmanship or materials. No warranty will apply if the wind generator (i) has been altered or modified except by Southwest Windpower, (ii) has not been installed, operated, repaired, or maintained in accordance with instructions supplied by Southwest Windpower (iii), or (iv) has been exposed to winds exceeding 140 mph (63 m/s), or has been subjected to abnormal physical, thermal or electrical stress, misuse, negligence, or accident. If Southwest Windpower’s repair facility determines that the problem with the wind generator is not due to a defect in Southwest Windpower’s workmanship or materials, then the party requesting warranty service will be responsible for the costs of all necessary repairs and expenses incurred by Southwest Windpower.

Warranty Claims & Return Procedures

In order to be eligible for service under this warranty the Customer MUST return the warranty registration card included with this Warranty Agreement within 60 days of purchasing the wind generator. Additionally, the Customer must submit a service request for the wind generator covered by this warranty within the warranty period by contacting Southwest Windpower in writing or via telephone and obtaining a Return Authorization (“RA”) number. This RA must be obtained before returning any product under this warranty. Notification must include a description of the alleged defect, the manner in which the wind generator was used, the serial number, and the original purchase date in addition to the name, address, and telephone number of the party requesting warranty service. Within 3 business days of the date of notification, Southwest Windpower will provide the Customer with a RA number and the location to which the Customer must return the defective wind generator. Any wind generator requiring warranty repair shall be transported at the expense and risk of the party requiring warranty service, including but not limited to proper packaging of the product. The Customer must return the entire wind generator kit within 30 days after issuance of the RA number. South-

west Windpower will be under no obligation to accept any returned wind generator that does not have a valid RA number. Customer’s failure to return the wind generator within 30 days of its receipt of a RA number may result in cancellation of the RA. All parts that Southwest Windpower replaces shall become Southwest Windpower’s property on the date Southwest Windpower ships the repaired wind generator or part back to the Customer. Southwest Windpower will use all reasonable efforts within five days of receipt of the defective wind generator to repair or replace such wind generator. If a warranty claim is invalid for any reason, the Customer will be charged at Southwest Windpower’s current rates for services performed and will be charged for all necessary repairs and expenses incurred by Southwest Windpower.

Disclaimer

EXCEPT FOR THE EXPRESSED WARRANTY SET FORTH ABOVE, SOUTHWEST WINDPOWER DISCLAIMS ALL OTHER EXPRESSED AND IMPLIED WARRANTIES, INCLUDING THE IMPLIED WARRANTIES OF FITNESS FOR A PARTICULAR PURPOSE, MERCHANTABILITY AND NON-INFRINGEMENT. NO OTHER WARRANTY, EXPRESSED OR IMPLIED, WHETHER OR NOT SIMILAR IN NATURE TO ANY OTHER WARRANTY PROVIDED HEREIN, SHALL EXIST WITH RESPECT TO THE PRODUCT SOLD UNDER THE PROVISIONS OF THESE TERMS AND CONDITIONS. SOUTHWEST WINDPOWER EXPRESSLY DISCLAIMS ALL LIABILITY FOR BODILY INJURIES OR DEATH THAT MAY OCCUR, DIRECTLY OR INDIRECTLY, BY USE OF THE PRODUCT BY ANY PERSON. ALL OTHER WARRANTIES ARE EXPRESSLY WAIVED BY THE CUSTOMER.

Limitation of Liability

UNDER NO CIRCUMSTANCES WILL SOUTHWEST WINDPOWER OR ITS AFFILIATES OR SUPPLIERS BE LIABLE OR RESPONSIBLE FOR ANY LOSS OF USE, INTERRUPTION OF BUSINESS, LOST PROFITS, LOST DATA, OR INDIRECT, SPECIAL, INCIDENTAL, OR CONSEQUENTIAL DAMAGES, OF ANY KIND REGARDLESS OF THE FORM OF ACTION, WHETHER IN CONTRACT, TORT (INCLUDING NEGLIGENCE), STRICT LIABILITY OR OTHERWISE, RESULTING FROM THE DEFECT, REPAIR, REPLACEMENT, SHIPMENT OR OTHERWISE, EVEN IF SOUTHWEST WINDPOWER OR ITS AFFILIATE OR SUPPLIER HAS BEEN ADVISED OF THE POSSIBILITY OF SUCH DAMAGE. (Note: some states and provinces do not allow the exclusion or limitation of incidental or consequential damages, so these limitations may not apply to you.) Neither Southwest Windpower nor its affiliates or suppliers will be held liable or responsible for any damage or loss to any items or products connected to, powered by or otherwise attached to the Hardware. The total cumulative liability to Customer, from all causes of action and all theories of liability, will be limited to and will not exceed the purchase price of the product paid by Customer. This Warranty gives the Customer specific legal rights and the Customer may also have other legal rights that vary from state to state or province to province.

Skystream 3.7[®] Technical Specifications

Model	Skystream 3.7
Rated Capacity	2400 Watts
Weight	170 lbs. / 77 kg
Rotor Diameter	12 feet / 3.72 meters
Swept Area	115.7 ft ² / 10.87 m ²
Type	Downwind rotor with stall regulation control
Direction of Rotation	Clockwise looking upwind
Blades	3 Fiberglass reinforced composite
Rated Speed	50 - 330 rpm
Shutdown Speed	370 rpm
Tip Speed	66 - 213 f/s / 9.7 - 63 m/s
Alternator	Slotless permanent magnet brushless
Yaw Control	Passive
Grid Feeding	120 / 240 Volt, 60 Hz, 2 Phase (split single phase); 120 / 208 Volt, 60 Hz, 3 Phase
Braking System	Electronic stall regulation w/redundant relay switch control
Cut-in Wind Speed	8 mph / 3.5 m/s
Rated Wind Speed	20 mph / 9 m/s
User Monitoring	Wireless 2 way interface remote system
Survival Wind Speed	140 mph / 63 m/s
Total Harmonic Distortion	2.7% at 2400W, meets UL1741 and IEEE1547.1 requirements IEC/EN 61000-3-2; Class A EU Limits; IEC 61400-21

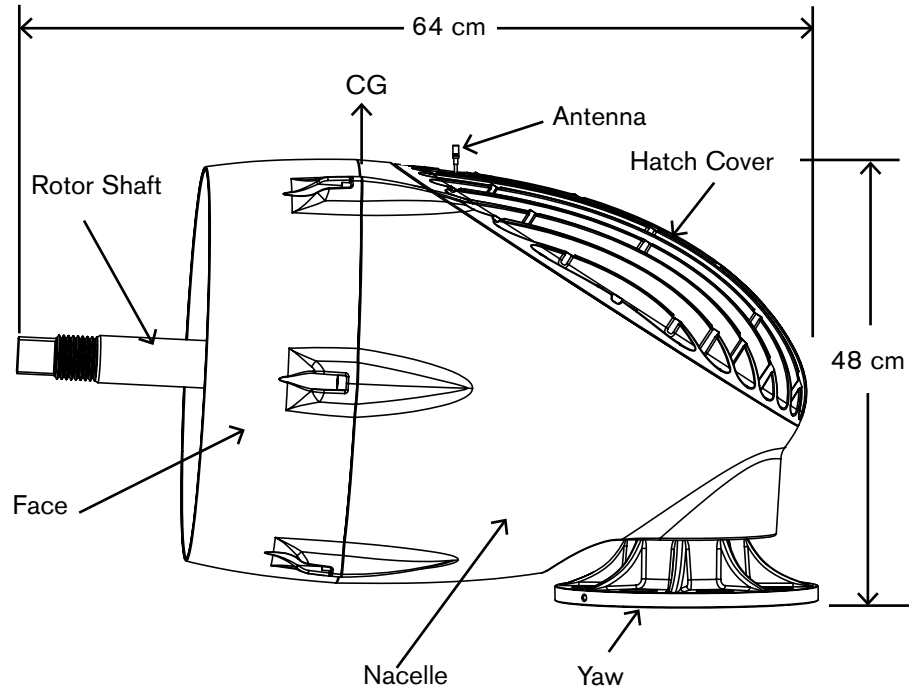

Frequency Accuracy	+/- 0.05 Hz
Voltage Accuracy	+/- 2.0 V (line to neutral)
Surge Rating	IEEE 1547 Surge Rating B European Requirement IEC 61000-4-5
Sound Pressure Level	46.4 dB at 60 m, 8 m/s

Skystream 3.7[®] Technical Specifications (continued)

Voltage and Frequency Trip Points

Condition	Configuration		Units
	-10	-11	
Voltage Stop, Minimum	105.6	105.6	Volts
Voltage Stop, Maximum	132.0	132.0	Volts
Voltage Fast Stop, Minimum	60.0	60.0	Volts
Voltage Fast Stop, Maximum	144.0	144.0	Volts
Voltage Start, Minimum	106.6	106.6	Volts
Voltage Start, Maximum	127.0	127.0	Volts
Frequency Stop, Minimum	59.3	59.3	Hz
Frequency Stop, Maximum	60.5	60.5	Hz
Frequency Start, Minimum	59.4	59.4	Hz
Frequency Start, Maximum	60.4	60.4	Hz
Minimum Start Time after Fault	300.0	300.0	Seconds
Configuration: USA Residential = -10 USA Commercial = -11			

Tower Data (Loads calculated at 145 mph - 65 m/s)

Note: Loads do not include safety factor. Southwest Windpower recommends minimum safety factor of 1.5

Shaft Thrust	630 lbs (2802 N)
Downward	210 lbs (932 N)
Bending Moment	1130 lb-ft (1532 N·m)

European Grid Standards

Skystream 3.7 complies with the relevant grid connection requirements taken from the following European Grid Codes:

- Verband der Elektrizitätswirtschaft – VDEW – e.V. “Eigenerzeugungsanlagen am Niederspannungsnetz” (generation units at low voltage level), 4th Edition, 2001, Germany
- ENA Energy Networks Association “Engineering Recommendation G83/1 – Recommendations for the connection of small-scale embedded generators (up to 16 A per phase) in parallel with the public low voltage distribution networks” September 2003
- EDF Référentiel Technique “Modele de Contrat de raccordement, d'accès et d'exploitation pour une installation de production de puissance ≤ 36 kVA raccordée au Réseau Public de Distribution basse tension Conditions Générales” / Standard Form Agreement for the Connection, Access and Operation of Power Generating Stations ≤ 36 kVA Connected to the Public Low Voltage Distribution Network General Terms and Conditions”, Référentiel technique – NOP-RES_55E, Version V6, 2006, France.
- DIN V VDE V 0126-1-1 (VDE V 0126-1-1) “Automatic disconnection device between a generator and the public low voltage grid”, February 2006 Germany.
- Italian Standard CEI 11-20 “Electrical energy production systems and uninterruptible power systems connected to LV and MV networks”
- ÖVE/ÖNORM prEN 50438 “ Requirements for the connection of micro-co generators in parallel with public low-voltage distribution system”, 01.10.2004

PRIOR TO INSTALLATION

Intended Use

Skystream 3.7 is a wind powered electricity generator containing an integral AC power inverter. It is designed to supplement the electrical power provided by the local electrical utility company in residential applications by connecting directly to the main AC utility panel. Skystream 3.7 may also be utilized to provide power with battery based residential electrical systems or utility grid connected systems with battery backup. A typical Skystream installation is depicted in Figure 1 of this manual.

Skystream 3.7 is designed to operate at sites with average wind speeds less than 8.5 m/s - IEC (International Electrotechnical Commission) Class II wind conditions. The installation of Skystream at sites with higher average wind speeds will accelerate component wear and require more frequent inspections.

Unintended Use

Utilizing Skystream 3.7 for other than its intended purposes or with inappropriate equipment or modifying Skystream is not authorized by Southwest Windpower and will void the warranty and may result in serious or even fatal injury. Observe the following precautions.

- Disconnect power to Skystream prior to servicing – observe “Lock-out” and “Tag-out” procedures.
- Observe all Electrical Code Requirements including tower grounding requirements, electrical disconnect switches, wire sizes and types. Reference the appendices in this manual.
- Skystream may only be installed on a tower approved by Southwest Windpower for use with Skystream. Do not install Skystream on roofs or on unauthorized towers.
- Do not use unauthorized fasteners. Use fasteners supplied with Skystream. Contact your dealer for authorized replacement fasteners.
- Observe fastener torque requirements.

- Do not attempt to modify Skystream in any fashion – internally or externally.
- Do not install blades other than those supplied with Skystream. Use only genuine replacement blades supplied by Southwest Windpower.
- Do not attempt to use a power source other than the wind to power Skystream – for example connecting pulleys or as water powered turbine.



IMPORTANT: Precautions listed here cannot address all the possible misuses of Skystream, therefore contact Southwest Windpower. If there is any doubt or question regarding the installation or use of Skystream.

Your Skystream Shipment Includes:

Your Skystream shipment includes the following components. For your convenience a small quantity of spare fasteners is included with each Skystream. The quantities indicated below are quantities required to assemble Skystream:

Turbine Assembly on Pallet

- Includes: turbine, nosecone, blade hub, blade plate (screwed to pallet), M42 hub mounting nut.

Blades (may be shipped separately)

- Blade mounting hardware
 - M10 x 120, grade 10.9, hex head bolts (quantity 12)
 - M10, grade 10.9, nut (quantity 12)

Nosecone Mounting Hardware

- M6 x 12 socket head screws, A2 stainless steel (quantity 3)

Skystream to Tower Mounting Hardware

- Vibration Isolators (quantity 8)
- Vibration Isolator Snubbing Washers (quantity 8)
- M12 x 90 hex head bolts, grade 10.9 (quantity 8)
- M12 nuts, grade 10.9 (quantity 8)

Yaw Shield

- Yaw shield halves (quantity 2)
- M5 x 12 socket head screws (quantity 4)

Strain Relief Cover

- Cover with ground wire (quantity 1)
- M5 x 12 socket head screws (quantity 4)

Miscellaneous

- RF antenna (quantity 1)

Skyview Interface Kit

- Permits remote monitoring of Skystream performance via personnel computer.

Skylevel Kit

- Enables accurate tower level when used with optional Skylevel Viewer Kit, part number 2-SSUP-106-02.



TIP: See exploded view on page 23

Installation Personnel

Southwest Windpower recommends professional installation of Skystream. While Skystream is not difficult to install, and many homeowners have successfully installed their own Skystream, knowledge of local zoning and building code requirements, construction techniques, as well as residential electrical systems is required for a safe installation.

Skystream dealers displaying the following insignia have completed factory training on the correct and safe installation of Skystream.

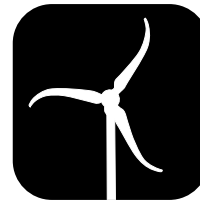

Skystream Dealer

Fig. 1 Typical Skystream Installation

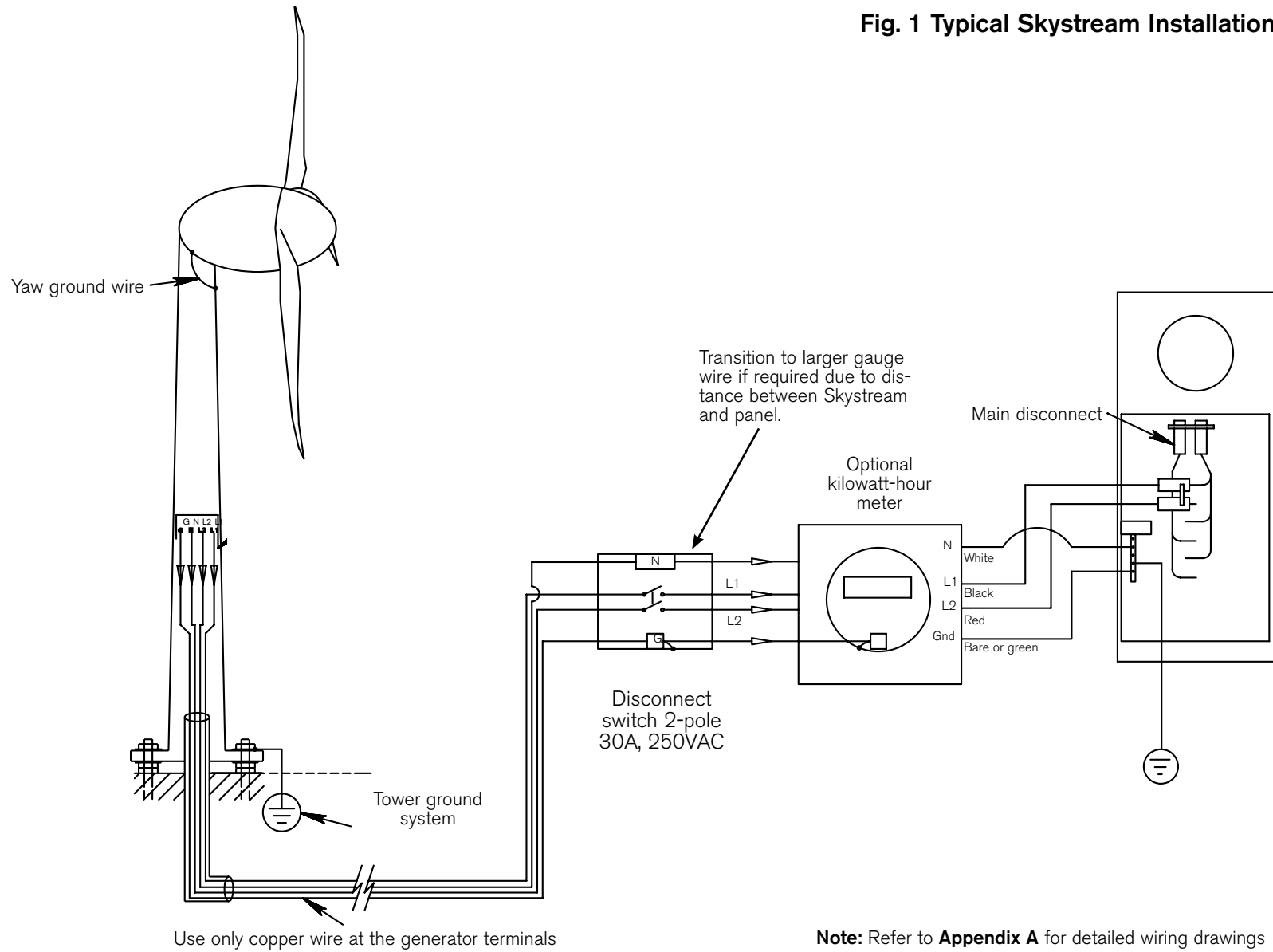

Note: Refer to **Appendix A** for detailed wiring drawings

Siting - Finding The Best Location For Skystream

The best location to install a wind turbine is often a compromise. Local building restrictions, the height of surrounding structures, wire length, and available open space may require Skystream be installed in a less than optimum location.

In general Skystream will produce more power if installed on a taller tower. However, towers are expensive so it is important to balance performance (tower height) to installed cost in order to achieve the lowest cost of energy and the quickest payback.

The General Rule: For optimal performance, install Skystream 20 ft (6.5 m) above any surrounding object within a 250 ft (75 m) radius. See figure below.



TIP: Your dealer can help you determine the best location for Skystream on your property.

Local Requirements

Building codes and installation regulations may vary greatly depending upon country, state, city and local townships. Be sure to obtain all the required building permits BEFORE beginning installation. Make sure you understand all inspection and installation requirements. Many locations may require installation by a licensed professional to meet building code requirements or to qualify for rebate incentives.

Additionally, be sure to contact the local electrical utility company. Many utility companies will require an "Interconnection Agreement" prior to installation. Some utilities may also require installation of a separate power meter for Skystream.



TIP: See our website: www.skystreamenergy.com for a sample interconnection agreement that may be used by a utility that has yet to establish a program.

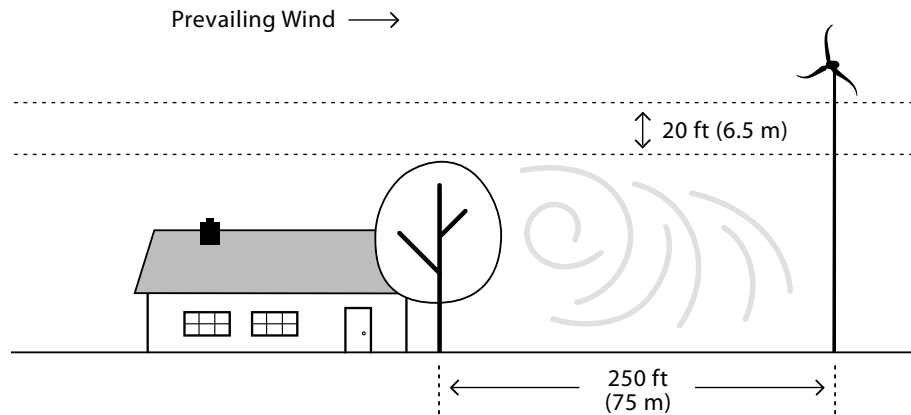

Optimal Skystream location.

INSTALLATION

Introduction

The following sections of this manual assume a tower and foundation appropriate for use with a Skystream are in place and ready for Skystream to be installed.

Southwest Windpower designed Skystream for easy installation by minimizing the number of electrical connections. In most cases Skystream may be connected directly to the electrical utility panel. However, local requirements may require installation of a disconnect switch and a second power meter between Skystream and the utility panel.

Wire Sizing

These wire sizing directions are for SINGLE Skystream turbine installations which are home-run to a main service panel.

DO NOT attempt to use these wire sizing instructions for a Skystream connected to a sub-panel or for multiple Skystreams together.

Note that the largest wire size that may be connected to the Skystream yaw terminals is #8 AWG (10 mm²). For installations requiring a larger wire size (because of distance) Southwest Windpower recommends using a disconnect switch box installed between the tower and utility panel to transition to a larger wire size.

To determine the appropriate wire size measure the total distance from the turbine to the electrical utility panel including the tower height and refer to the tables below.

Table 1 includes maximum wire length information for wire sizes #8 AWG and smaller without transitioning to a larger wire size. Select the appropriate wire size based on the total wire length and Skystream voltage configuration (240 VAC, split phase or 208 VAC, 3 phase).

If the required wire length is greater than can be accomplished with #8 AWG wire refer to Table 2. This table includes wire size information for

installations requiring a transition to a wire size larger than #8 AWG.

Table 2 provides for a 75 ft length of # 8 AWG wire to be run from the Skystream yaw to a disconnect switch box and a length of #4 or # 6 AWG wire to be run from the disconnect switch box to the utility panel. Select the appropriate wire size combination based on the of wire run length and Skystream voltage configuration.

Note if needed the 75 ft length of #8 AWG wire may be shortened and the larger gauge wire lengthened a corresponding amount. However, DO NOT lengthen the #8 AWG wire and lengthen the larger gauge wire.

Table 1

Wire Size	120/240 VAC, Split Phase	120/208 VAC, 3 Phase
4 AWG (25 mm ²)	See Table 2	See Table 2
6 AWG (16 mm ²)	See Table 2	See Table 2
8 AWG (10 mm ²)	303 ft (92 m)	264 ft (80 m)
10 AWG (6 mm ²)	190 ft (58 m)	165 ft (50 m)
12 AWG (4 mm ²)	120 ft (37 m)	104 ft (32 m)
14 AWG (2.5 mm ²)	75 ft (23 m)	65 ft (20 m)

Use copper conductors only - Minimum wire temperature rating is 75°C (167°F). Distances and wire sizes are based on 2400 W power production and maximum 2% voltage rise at the turbine.

Table 2

System Voltage	Maximum Wire Length	# 8 AWG	# 6 AWG	# 4 AWG
120/240 VAC, Split Phase	650 ft (198 m)	75 ft (22.9 m)	-----	575 ft (175 m)
120/240 VAC, Split Phase	435 ft (13 m)	75 ft (22.9 m)	360 ft (110 m)	-----
120/208 VAC, 3 Phase	550 ft (168 m)	75 ft (22.9 m)	-----	475 ft (145 m)
120/208 VAC, 3 Phase	375 ft (114 m)	75 ft (22.9 m)	300 ft (91 m)	-----



Warning: For your safety, make sure power is turned off before working on any and all electrical connections.

Grounding

All electrical systems must be grounded in accordance with local and national standards. Grounding provides protection from lightning, electrical shock, voltage surges and static charge build up.

The figures in **Appendix A** provide information for grounding the tower and Skystream at the service panel by means of the ground lead coming from the yaw terminals of the turbine.

Appendix B provides information for grounding the tower according to the National Electric Code (USA) and IEC 60364-5-54. Information about grounding electrodes, grounding conductors, and connections is provided. The turbine must be grounded to the tower as depicted in Figure 2.

Note: The AC input and AC output circuits are isolated from the enclosure and system grounding, if required by Section 250 of the National Electrical Code, ANSI / NFPA 70, is the responsibility of the installer.

The AC output / neutral is not bonded to ground inside of the wind turbine.

The instructions in this section and Appendix A are provided as reference; local electrical codes and standards have precedence over these instructions.

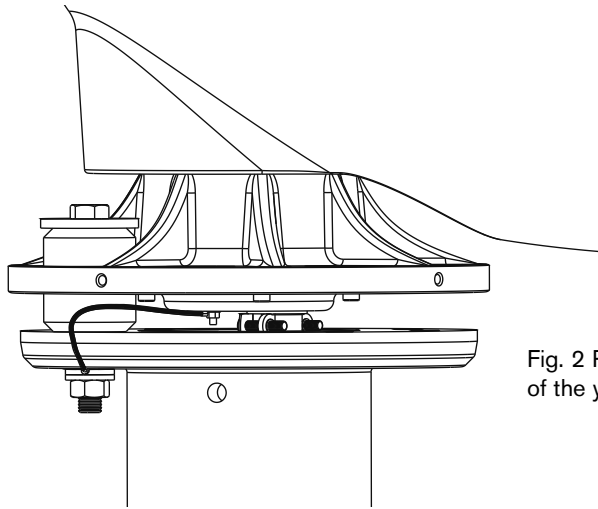

Fig. 2 Proper grounding of the yaw connection

Utility Panel Connections

Skystream connects directly into your electrical panel. Wiring will vary with local zoning authority and utility. Refer to **Appendix A** for drawings for each voltage, frequency and phase configuration. Some installations will require a visible lockable disconnect switch located next to the electrical meter and/or at the base of the tower. The disconnect switch is utilized by your local utility in the event of a power outage to ensure no voltage is placed on the utility line during repair. Again, it is extremely important to install in accordance with local and national zoning regulations.

WARNING:

To reduce the risk of fire, do not connect Skystream to an AC Load Center (circuit breaker panel) on a branch circuit where multi-wire branch circuits are connected.

CAUTION:

To reduce the risk of fire, connect only to a circuit provided with 20 amperes maximum branchcircuit overcurrent protection in accordance with the National Electrical Code, ANSI/ NFPA 70.

CAUTION:

Overcurrent protection for the AC output circuit is to be provided by others.



IMPORTANT: Install the Skylevel “spider” on the tower top prior to connecting the power wires to Skystream yaw. The wires must pass through center of “spider” as shown in accompanying photograph.



Fig. 3 Skylevel “spider”

Electrical Connections to Skystream



Caution: Turn power OFF prior to making electrical connections. Use a locking disconnect switch to disconnect power and LOCK it when making connections!

The following section provides directions for completing the main power connections to the Skystream.

Warning: Southwest Windpower strongly recommends and many local electrical authorities require a lockable disconnect switch (Figure 4) installed between the Main Service Panel and Skystream.

Turn the switch to “Off” and lock the switch to prevent turning on the power before it is safe to do so.

The connections are most easily accomplished with Skystream on the ground as would be the case when utilizing a tilt-up tower. If the installation does not incorporate a tilt-up tower, the connections may still be made on the ground by utilizing a sufficient length of cable to connect Skystream to the nearest junction point.



Fig. 4 Typical Locking Disconnect Switch

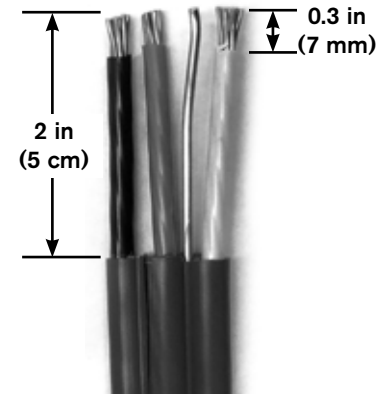

Fig. 5 Insulation removal

Refer to the accompanying photographs and perform the following steps:

- Install the Skylevel “spider” and cable as directed in the Skylevel instructions. Refer to Figure 3.
- The “spider” contains a sensor that will be used to during the tower leveling process.
- Position Skystream on its side to access the yaw wire terminals.
- Remove approximately 0.3 inch (7 mm) of insulation from each of the Skystream yaw wires.
- Remove approximately 2 inches (5 cm) of cable jacket from the cable to be run down the tower and strip approximately 0.3 inch (7 mm) of insulation from the individual wires See Figure 5.
- **Note:** The maximum wire size that can be connected directly to Skystream is # 8 AWG (10 mm²). Refer to Wire Sizing Section of this manual for instructions on selecting correct size wire.
- Pass the cable through strain relief clamp so approximately 0.5 in (1.5 cm) of cable jacket protrudes past the clamp. Tighten the strain relief clamp screws to secure the tower cable.
- Connect each of the tower wires to the terminal block as shown in the accompanying photo. Tighten the terminal block screws to 23-25 in lb (2.5-2.8 N·m). See Figure 6 or 7, as appropriate.
- Install the terminal block – cover assembly on Skystream using the socket head screws provided. Tighten screws to 20-22 in lb (2.3-2.5 N·m).

After making the yaw wire connections, temporarily turn on power and immediately attempt to rotate the blade shaft; the shaft should initially be difficult to rotate but become noticeably easier after 5 minutes.

Disconnect the power and verify that Skystream has returned to its “braked” mode. In the “braked” mode the blade shaft should once again be difficult to turn.

Table 3

Wire Function	Wire Color, IEC	Wire Color, NEC (USA)
Protective Ground	Green with Yellow Stripe	Bare, Green, or Green with Yellow Stripe
Neutral	Blue	White
Line, Single Phase	Brown	Black or Red (2 nd hot)
Line 1, 3 Phase	Brown	Black
Line 2, 3 Phase	Black	Red
Line 3, 3 Phase	Grey	Blue

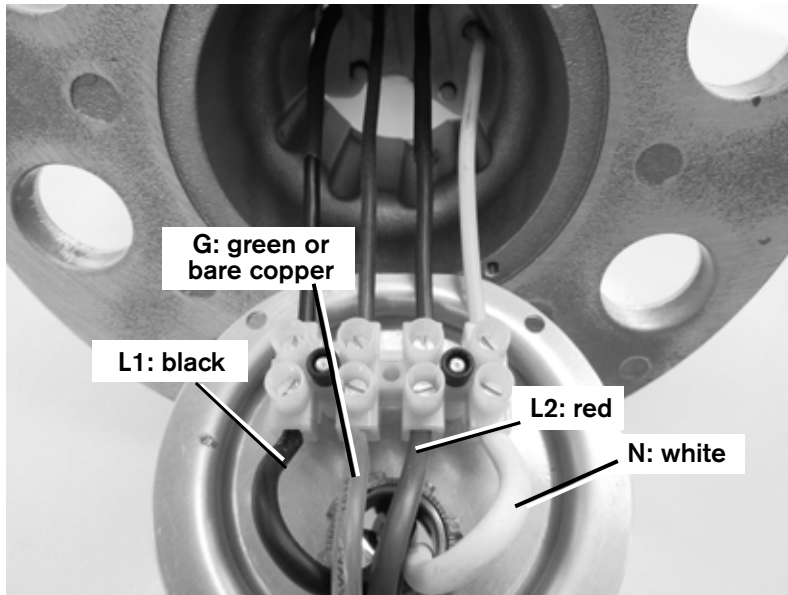

Fig. 6 240/208V Yaw wiring (USA Wiring Depicted, connect Red to Red, Black to Black)

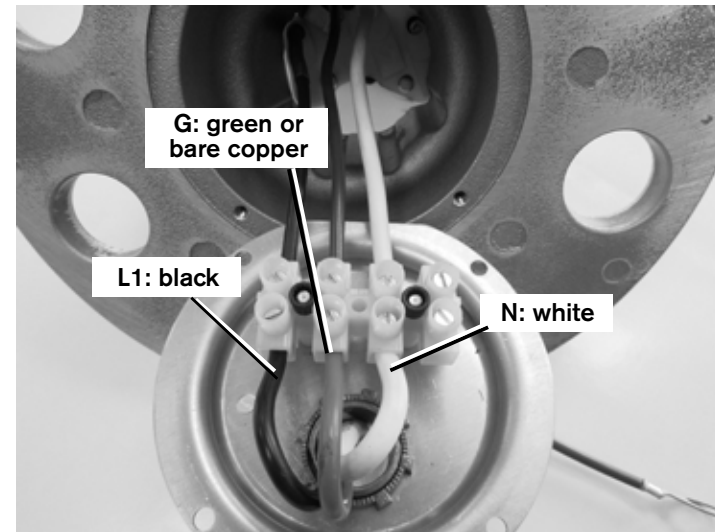

Fig. 7 120V Yaw wiring See note below:

Note: The 120 Volt model of Skystream (Part Number 1-SSL-10-120 (land) or Part Number 1-SSM-10-120 (marine) is NOT Underwriters Laboratories (UL) Recognized and MAY NOT be connected to the electric utility grid.

Note: The color of the power wires (originating from the Skystream yaw housing) follow the US National Electric Code (NEC) and International Electrotechnical Commission (IEC) mandates and conventions as indicated in Table 3.



Caution: Make sure AC power is switched “OFF” before proceeding with installation.

Lightning Protection

The Skystream 3.7 turbine is designed to withstand over voltages and surge currents (6kV, 3kA, 8/20µs) caused by INDIRECT lightning strikes or switching operations according to the Standard for Interconnecting Distributed Resources with Electric Power Systems (IEEE 1547) . For this protection to be effective, it is necessary to ensure that over voltages at the Skystream connection terminals will not be higher than the above values of the surge test.

To provide this over voltage protection against **DIRECT** lightning strikes; a **Type 1 lightning current arrester**, that reduces over voltages to a level below 6 kV but is capable of discharging very high currents, much larger than those handled by surge protective devices present inside Skystream is required.

Note: Refer to Appendix C for specific instructions on the selection of a Lightning Protection System.

Installing Skystream on a Tower

There are several types of towers that can be used with Skystream. It is essential that Skystream is installed on a properly engineered tower. One of the leading causes of wind generator failure is use on a poorly designed tower.

Regardless of the tower design and height you select, there are two critical areas that must be considered when selecting the tower. These are the stub tower height and blade clearance; refer to accompanying figure.

Note: The orientation of the vibration isolators is very important. Refer to **Figs. 10, 11 & 12.**



Warning: Working on towers is dangerous and should be left to professionals with proper safety equipment and training.



IMPORTANT: Southwest Windpower's Warranty is only extended to installations that are made on a properly engineered tower. Southwest Windpower reserves the right to deny any warranty claim in which an improperly designed tower is used.

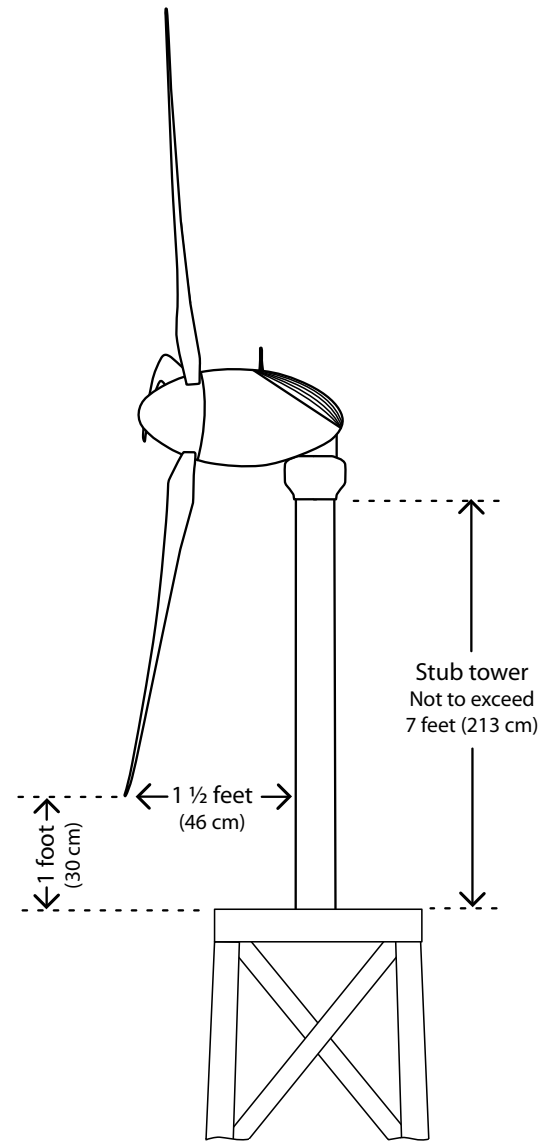

Critical turbine blade clearances

Bolting Skystream to the Tower

The following section provides directions for bolting Skystream to the tower. Before Skystream is bolted to the tower complete the electrical connections as described in the “ELECTRICAL CONNECTIONS” section of this manual.

Bolting Skystream to the tower is most easily accomplished at ground level as in the case with a tilt-up tower. Alternately Skystream may be bolted to the tower on the ground, and the tower with Skystream hoisted into position as an assembly; or Skystream may be hoisted to an already erected tower. These latter two options require specialized equipment and training and should only be attempted by trained professionals.

- Install the vibration isolator halves (items 4 and 5) on the yaw as shown in **Fig. 12**. Note the orientation of the isolator halves is very important – install as shown.
- Insert the vibration isolator bolts and snubbing washers into the vibration isolators from “above” as shown in **Fig. 12**.
- Using an appropriate lifting device, lift Skystream and align vibration isolator bolts with holes in the tower flange.

Note: A wide nylon lifting strap may be used to hoist Skystream into position. The strap **MUST** cinch or “choke” the turbine tightly prior to hoisting. Refer to the accompanying figure for positioning the strap along the center of gravity.



Warning: Do not attempt to hoist a tower and Skystream into position using a sling attached to Skystream; Skystream **CANNOT** support the hanging weight of a tower.

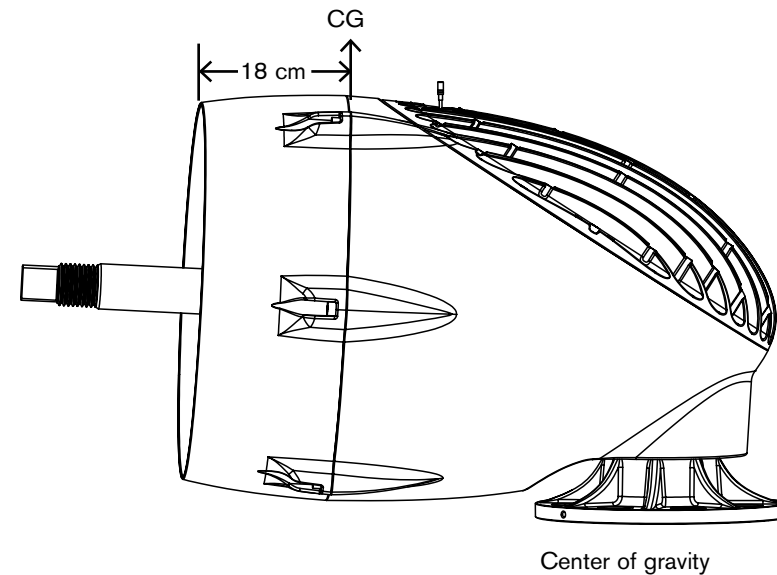

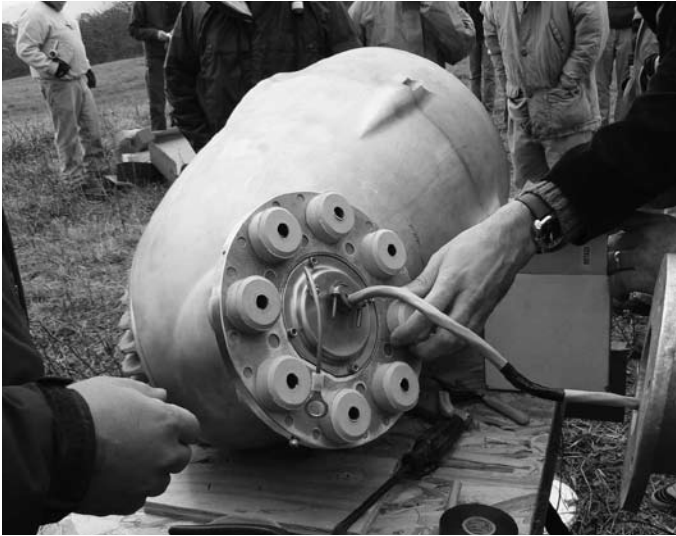

Fig. 10 Placing vibration isolators



Fig. 11 Grounding turbine to tower

- Install nuts on bolts to secure Skystream to the tower.
- Connect the turbine ground wire as depicted in **Fig. 2**. The turbine **MUST** be grounded to the tower as shown.
- Torque the vibration isolator bolts to 60 lb-ft (80 N·m) in two steps. First torque all bolts to 40 lb-ft (55 N·m) then tighten all bolts to 60 lb-ft (80 N·m).
- Mount the yaw shield halves using four M5 socket head screws. Refer to **Fig. 12**.

Installing the Blades (Hub Not on Turbine)

Proper installation of the blades is critical for safe operation. The blade nuts and bolts are a unique grade of steel and are specially coated to prevent corrosion. DO NOT substitute different nuts and bolts. Spare nuts and bolts are provided with Skystream.

Carefully follow these instructions to obtain secure bolted joints and maximum corrosion protection, particularly in corrosive marine environments.

- Start the assembly by positioning a blade between the blade hub and blade plate. The blades may only be installed in one position due to the triangular boss cast into one side of the blade root.
- Install the bolts by passing the bolt through the BLADE PLATE and AWAY from the NACELLE as shown in **Fig. 13**.
- Leave the nuts loose until all blades are installed and then tighten the bolts just enough to clamp the blades between the hub and plate.



IMPORTANT:

- Do NOT substitute nuts, bolts or washers. Contact SWWP for replacements.
- DO NOT apply lubricants to nut or bolt threads.
- RECHECK bolt torque after tightening bolts.

Bolt Tightening Sequence

- Torque the blade bolts to 50 lb-ft (68 N·m) in two stages.
- Following the Blade Bolt Tightening Sequence shown – torque each bolt to 30 lb-ft (41 N·m) in two stages.
- After completing first stage, following the Blade Bolt Tightening Sequence, and tighten each bolt to 50 lb-ft (68 N·m).
- After completing the second tightening stage RECHECK each bolt is tightened to 50 lb-ft (68 N·m).
- The blades are now assembled to the hub and ready for installation onto the turbine rotor shaft.
- Coat the inside diameter of the blade hub with a multipurpose lithium grease to prevent corrosion between the hub and shaft.
- Position the hub nut in the center of the blade hub and slide the entire hub / blade assembly onto the shaft and “spin” the entire assembly to screw the hub onto the shaft.
- Tighten the blade hub assembly to 200 lb-ft (270 N·m) by holding the blades and using the “flats” on the rotor shaft.

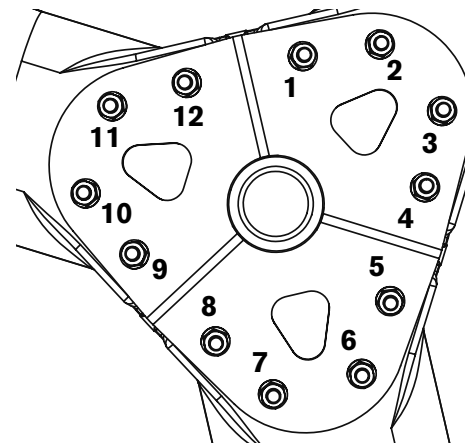

Blade bolt tightening sequence

Installing the Nosecone and Antenna

- Install the nosecone with three M6-1.0 socket head bolts.
- Install RF Antenna on matching fitting on top of Skystream. Fingertight is sufficient.

Important: Do Not Forget to Install RF Antenna

RF antenna is required for communication with Skystream by the Skyview. Even if you do not intend to use Skylevel be sure to install antenna as it service personnel may be able to diagnose and upgrade your Skystream via Skylevel without removing it from the tower.

Final Electrical Tests (Tilt-Up Towers)

At this point Skystream should be bolted to the tower and all the ancillary equipment – blades, nosecone, yaw shield, and antenna – attached.

Prior to tilting the tower into position, the following final electrical tests should be performed:

- With power turned off attempt to rotate the blades – there should be noticeable resistance although the leverage provided by the blade will make it possible to rotate the blades.
- Turn on power and attempt to rotate the blades after approximately 5 minutes. There should be noticeably less resistance required to rotate the blades.
- Turn off the power and verify that Skystream returns to a “braked” condition.
- Verify Skystream is grounded to the tower by measuring the resistance between the nacelle (use an unpainted bolt head in the case of marine units) and the tower flange. The resistance must ≤ 1 ohm.

Do not attempt to put Skystream into service until these tests pass. If tests pass, tower may be tilted into position and placed into service.

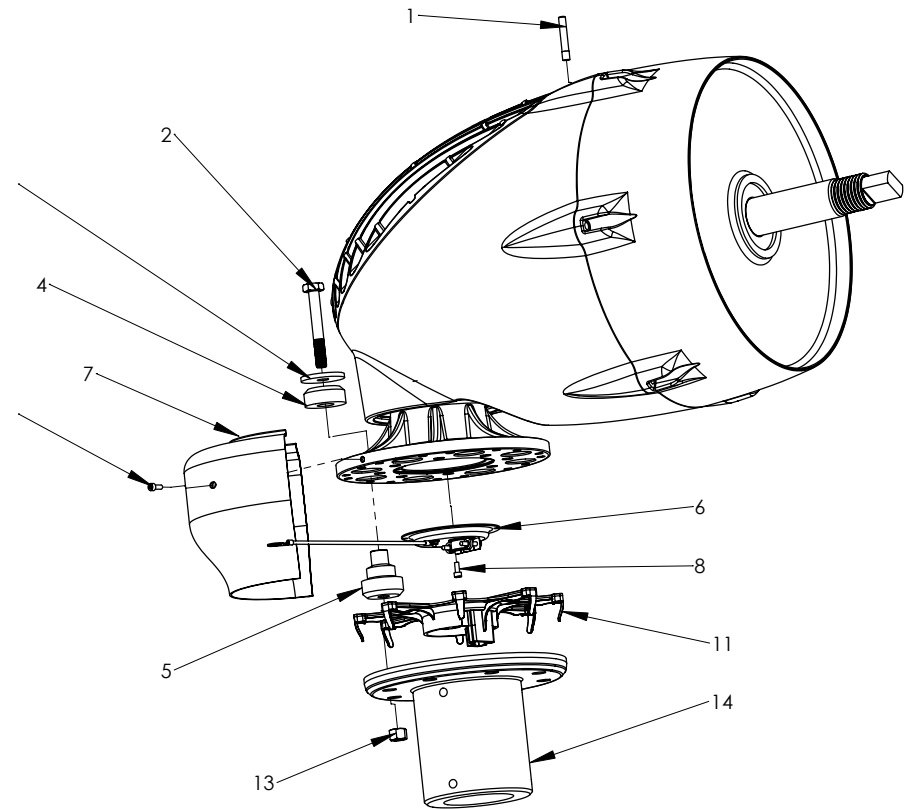

Fig. 12 Yaw and antenna assembly

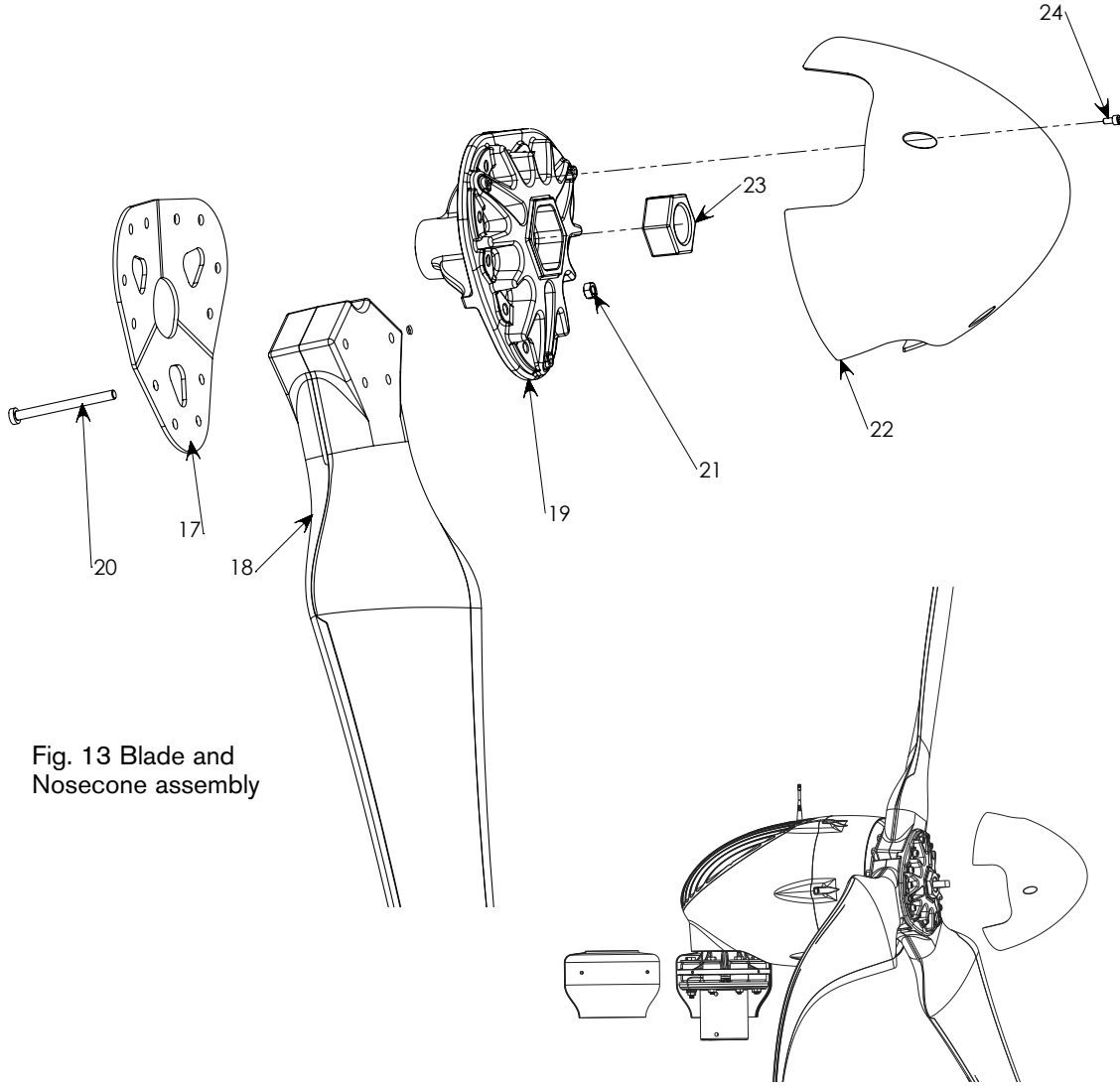

Fig. 13 Blade and Nosecone assembly

#	DESCRIPTION	QTY.
1	RF Antenna	1
2	M12 x 1.75 x 90mm Hex Bolt Grade 10.9	8
3	Snubbing Washer	8
4, 5	Vibration Isolation Ring (4) and Bushing (5)	8
6	Strain Relief Cover Assembly	1
7	Yaw Shield	2
8	M5 x 12mm Socket Head Screw	8
11	Skylevel Assy.	1
13	M12 x 1.75 Nut grade 10.9	8
14	5" Tower Insert (optional)	1
17	Blade Plate	1
18	Blade	3
19	Blade Hub	1
20	Hex head bolt, M10, grade 10.9	24
21	Hex nut, M10, grade 10.9	12
22	Nosecone	1
23	Hub Retaining Nut grade 10.9	1
24	M6 x 1 x 12mm Bolt SHCS grade 8.8	3

Fig. 14 Completed assembly

OPERATION

Manual Operation of Skystream

Manual operation of Skystream is limited to starting and stopping using the circuit breakers at the electrical utility panel or electrical disconnect switch if equipped. To stop Skystream, switch the circuit breakers to “OFF;” and to restart Skystream switch the circuit breakers to “ON.” Note that Skystream may require approximately 5 minutes to restart after the circuit breaker is switched “ON.”

An “ATTENTION” label, depicted below, is provided to indicate the location of the AC power disconnect switch or circuit breakers. Apply the label in a prominent location where it will be seen by operators or service personnel.



Maintenance

After 20 years of service the blades MUST be replaced – even if there is not apparent damage. The blades should be replaced as a set. Do not attempt to replace individual blades. All blade mounting hardware – bolts, nuts and washers – should be replaced at the same time. Do NOT attempt to reuse the blade fasteners.

There are no periodic service requirements other than replacing the blades after 20 years. All bearings and rotating components were designed for

a 20-year life at an IEC Wind Class II site, under the IEC 61400-2 Small Wind Safety Standard. This corresponds to a site with an average wind speed of 8.5 m/s.

Although there are no routine service or maintenance requirements, Skystream owners should be observant of any unusual sounds, vibrations or erratic behavior. If unusual behavior is noticed, the best course of action is usually to shut down the turbine and contact the dealer or service center.

One area of Skystream that may experience damage is the blades, for example from flying debris during a high wind storm. For this reason Southwest Windpower recommends Skystream be shut down on an annual basis and an inspection of the blades performed. The inspection may be accomplished using binoculars or by close visual inspection. Inspect for cracks and chips particularly along the edges of the blades. Any damage is cause for replacing the blades. If in doubt, contact your local service center.

In the event you must gain access to Skystream, use the opportunity to perform the following inspections:

- Remove yaw shield and verify yaw bearing snap ring is properly seated. Wipe any grease that may have seeped from yaw bearing. A small amount of lubricant is normal – consult technical support if there is large amount of leakage.
- Check that the hatch cover bolts are tight. Bolts should be tightened 60 in lb (7 N·m).
- Check the tightness of the (8) yaw bolts with a torque wrench. All yaw bolts should be torqued to 60 lb-ft (80 N·m).
- Reinstall the yaw shield and secure the fasteners.
- Check tightness of blade bolts with torque wrench. All blade bolts should be torqued to 50 lb-ft (68 N·m).
- Clean the rotor blades with a mild soap and water. Remove as much of the dead bug matter as possible from the blades.
- Look for any problems with the blades such as cracks or damage to the edges of the rotor blade.
- Inspect the face, nacelle, and the rest of the Skystream, and note any potential damage or problem.

Service

The internal components of Skystream should only be serviced by qualified technicians specifically trained to perform the service. Under no circumstances should untrained technicians attempt to perform service or repairs unless under the direct guidance of a trained technician.

Service operations that were performed during the installation of Skystream, for example bolting on the blades or bolting Skystream to the tower may be performed as necessary by the user / operator.

Emergency Shutdown

If Skystream's internal microprocessor determines a serious internal fault has occurred, it will execute an Emergency Stop – an E-Stop. An E-Stop will only take place if the fault is severe and requires servicing Skystream's internal components. Refer to the Key Operating Characteristics section of this manual for a complete description of the Skystream's various "shut down" modes including Emergency Stops.

Resetting an Emergency Stop requires special equipment and can only be accomplished by a trained technician. If you suspect your Skystream has executed an Emergency Stop, contact Skystream Technical Support.



Warning: There is risk of electric shock from both AC and DC voltages within Skystream. Do not attempt to remove the hatchcover to access the internal components. AC power should always be disconnected, the turbine restrained from yawing, and blades secured from rotating prior to servicing or serious or fatal injury may occur.

KEY OPERATING CHARACTERISTICS

The Skystream 3.7 operates by converting the kinetic energy of the wind into rotational motion that turns an alternator and ultimately produces usable electric power. In actuality this is a great oversimplification of Skystream's operation since it must very precisely match the frequency and voltage of the electricity supplied by the local utility company in order to power your home and its appliances. Additionally, Skystream monitors and adjusts its performance to provide safe operation and extract the maximum energy from even low speed winds.

Skystream will begin producing power in a wind of approximately 3.5 m/s. At that speed the blades will rotate at approximately 120 rpm. Once it has started producing power, it will continue to produce power at lower speeds down to 80 rpm and less than 3 m/s. As the wind speed increases, the blade speed will also increase. At about 9 m/s the blades achieve a rotational speed of 330 rpm. This is Skystream's rated speed. Should the wind speed increase above 9 m/s, the blade speed will remain essentially fixed at 330 rpm. If a condition occurs that causes the rotational speed to exceed 360 rpm, Skystream will shut down for approximately 10 minutes after which it will resume normal operation unless a fault is detected causing it to remain shut down. This is an unlikely scenario that should never occur in normal operation.

If a wind gust exceeds 25 m/s, then the Skystream will shut down for 1 hour. After 1 hour, the Skystream will turn back on and resume normal charging. If the wind is still above 25 m/s, then the Skystream will shut down for another hour.

In addition to adjusting its operation in response to wind conditions, Skystream also monitors the electrical utility grid and its own internal health. Should the electric utility voltage or frequency differ from Skystream's voltage, for example due to a power failure, Skystream will disconnect from the grid and enter a "braked mode." While in this mode the blades are held stationary while the Skystream monitors the utility power. If Skystream determines that the power has returned to within specification, it will re-connect to the grid and resume normal operation. This is the same

cycle that occurs when Skystream is initially powered. Additionally, should Skystream determine an internal fault exists, it will execute an emergency shutdown – an E-stop. An E-stop will only take place if a severe fault that requires servicing internal components has occurred. For that reason resetting an E-stop requires gaining access to the interior of Skystream. It cannot be reset from the ground.

Electronic Stall Regulation

The Skystream 3.7 has the ability to adjust the rotational speed of its blades or even stop the blades if required by ambient conditions. This is referred to as Stall Control, and it is accomplished by adjusting the current draw from the alternator. The higher the current draw, the greater the electromagnetic torque applied to the rotor, and if enough torque is applied, the blades will slow or even stop. In simple terms the inverter is demanding more power than the available wind can provide thus causing the blade rotational speed to decrease.

As a safety feature, the alternator is capable of producing approximately five times the torque required to control the turbine. This extra available power means that even if segments of the alternator windings are damaged, there is still sufficient torque to stop the turbine.

While Skystream is connected to the utility grid it constantly monitors that all conditions, for example grid voltage and frequency, are within limits. If the inverter determines that all operating conditions are within limits, it opens three Normally Closed (NC) relays, RL1, 2 and 3, removing the short from the alternator windings and allowing the blades to spin freely.

Only then will it operate the DPDT Grid Relay RL_G to allow the inverter to export power to the grid. Refer to the Skystream Block Diagram in Appendix A. Should the inverter sense an abnormal condition, for example high current in the alternator windings by means of the current sensors on the relay board, it will close relays RL1, 2, and 3 thereby stopping the turbine. In turn, the DPDT Relay RL_G will be operated to the position where the inverter power exporting circuitry is disconnected from the grid.

Redundant Relay Switch Control

As a redundant measure of safety to guarantee stopping the turbine in case of a winding fault or a lost connection to the alternator, there are seven connections to the alternator windings, but only three are necessary to control or stop the turbine. And as a final measure of safety, if the inverter is unable to control the rotational speed and Skystream exceeds approximately 400 rpm, the rectified voltage will exceed the Zener (Z) voltage on the relay board, causing the latching relay (RL4) to open. This will cause the relays RL1, 2, and 3 to close and apply all the available electromechanical torque to the rotor, stopping Skystream completely. The inverter power path will also be disconnected from the grid by means of relay RL_G. This is the final level of control and is only applied when all other methods of control have failed. As such, once set, (latched) RL4 may only be reset by gaining internal access to Skystream – it cannot be reset via the Remote Display.



Warning: Power to Skystream MUST BE TURNED OFF prior to servicing.

Disposal of Skystream

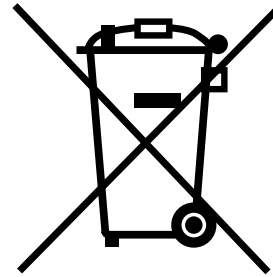

This symbol shown on Skystream or its packaging indicates it may not be treated as household waste. Dispose of Skystream properly by handing the entire turbine assembly over to the applicable collection point for recycling of electrical equipment.

By ensuring Skystream is disposed of correctly, you will help prevent harm to the environment, which may be caused by inappropriate disposal of this product. The recycling of materials will help conserve natural resources. For more detailed information about recycling of Skystream, please contact your local waste disposal authorities, your household waste disposal service or the store where you purchased Skystream.

Skystream was manufactured in compliance with the Restriction of Certain Hazardous Substances in Electrical and Electronic Equipment 2002/95/EC (RoHS) and therefore does not contain any of the materials regulated by that standard.

Frequently Asked Questions

1) What happens if I lose power from my utility company?

If there is a power outage the Skystream will shut down within one second. It will resume normal operation when power is restored. There are many safety requirements of a utility-tied inverter. The Skystream meets all of these requirements per UL 1741 and IEEE 1547 and appropriate European Regulations.

2) Does Skystream have lightning protection ?

Yes, Skystream has lightning protection. Skystream can withstand 6000 volts as required by UL 1741, IEEE 1547 and appropriate European Regulations. However, if you live in a lightning prone area Southwest Windpower recommends an additional lightning arrestor at the base of the tower.”

3) When should I contact an authorized service technician?

- a) If “Growling” noise is detected turn Skystream “OFF” and contact Technical service.
- b) If frequent “shut-downs” are observed.
- c) Unusual noises or vibrations are observed. Use caution. If in doubt turn Skystream “OFF” and contact Technical service.
- d) Circuit breaker and switches are turned “ON” and Skystream is not turning in response to wind.

4) What should I do if I'm expecting a severe storm?

The Skystream is designed for very high winds, but it is always a good idea to shut Skystream down if there is going to be a severe storm to protect against any flying debris.

5) How do I shut down Skystream?

To turn off Skystream, all you need to do is turn off the breaker Skystream is connected to. This will cause NO damage to the unit.

6) Can I leave Skystream unattended?

Yes, the Skystream is designed to operate without any user input. If there is any fault, it will shut down on its own.

7) What do I do if Skystream is facing upwind even though there is a strong wind?

If the Skystream is not tracking correctly, you should check to see if the tower is level.

8) Can I mount Skystream to my roof?

Roof and building mount is not recommended. Because of the size and weight of the wind generator, Skystream needs to be mounted on a PE certified tower to ensure the quietest and safest system. Roof mounting will invalidate the warranty.

9) What should I do if ice forms on Skystream blades?

To avoid the possibility of injury from ice breaking loose from the blades and injuring anyone, Skystream should be turned OFF if ice accumulates on the blades.

SKYSTREAM 3.7[®]

APPENDIX A: ELECTRICAL DIAGRAMS

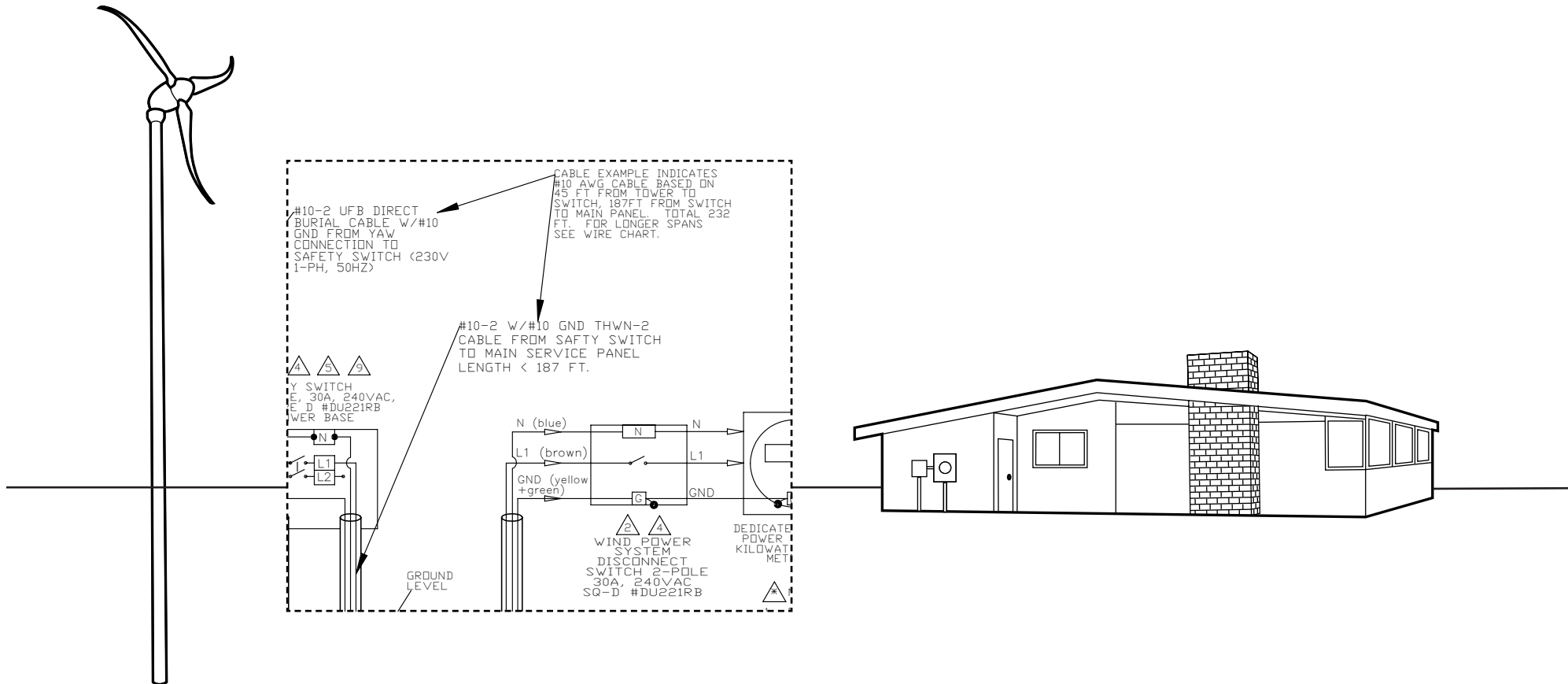

Skystream 3.7[®] Owner's Manual

Appendix A: Electrical Diagrams

1)	GRID CONNECTION OPTION A: 120/240 V, 60 Hz, Split Phase, Junction Box at Tower Base _____	3
2)	GRID CONNECTION OPTION B: 120/240 V, 60 Hz, Split Phase, Without Junction Box at Tower Base _____	4
3)	GRID CONNECTION OPTION C: 120/208 V, 60 Hz, 3 Phase, Junction Box at Tower Base _____	5
4)	GRID CONNECTION OPTION D: 120/208 V, 60 Hz, 3 Phase, Without Junction Box at Tower Base _____	6
5)	SKYSTREAM BLOCK DIAGRAM _____	7

Fig. 1. Grid Connection Option A: 120/240 V, 60 Hz, Split Phase, Junction Box at Tower Base

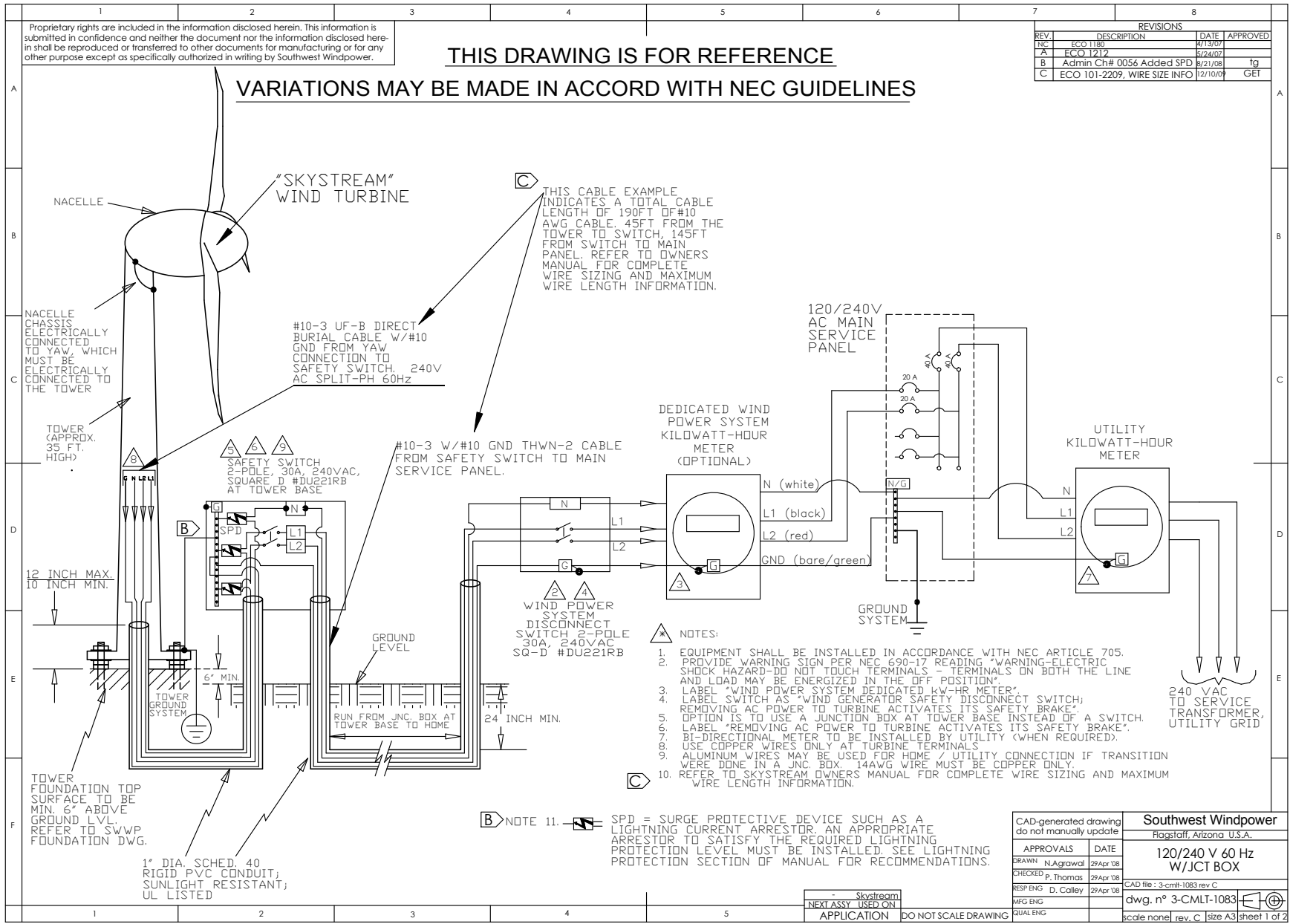

Fig 2. Grid Connection Option B: 120/240 V, 60 Hz, Split Phase, Without Junction Box at Tower Base

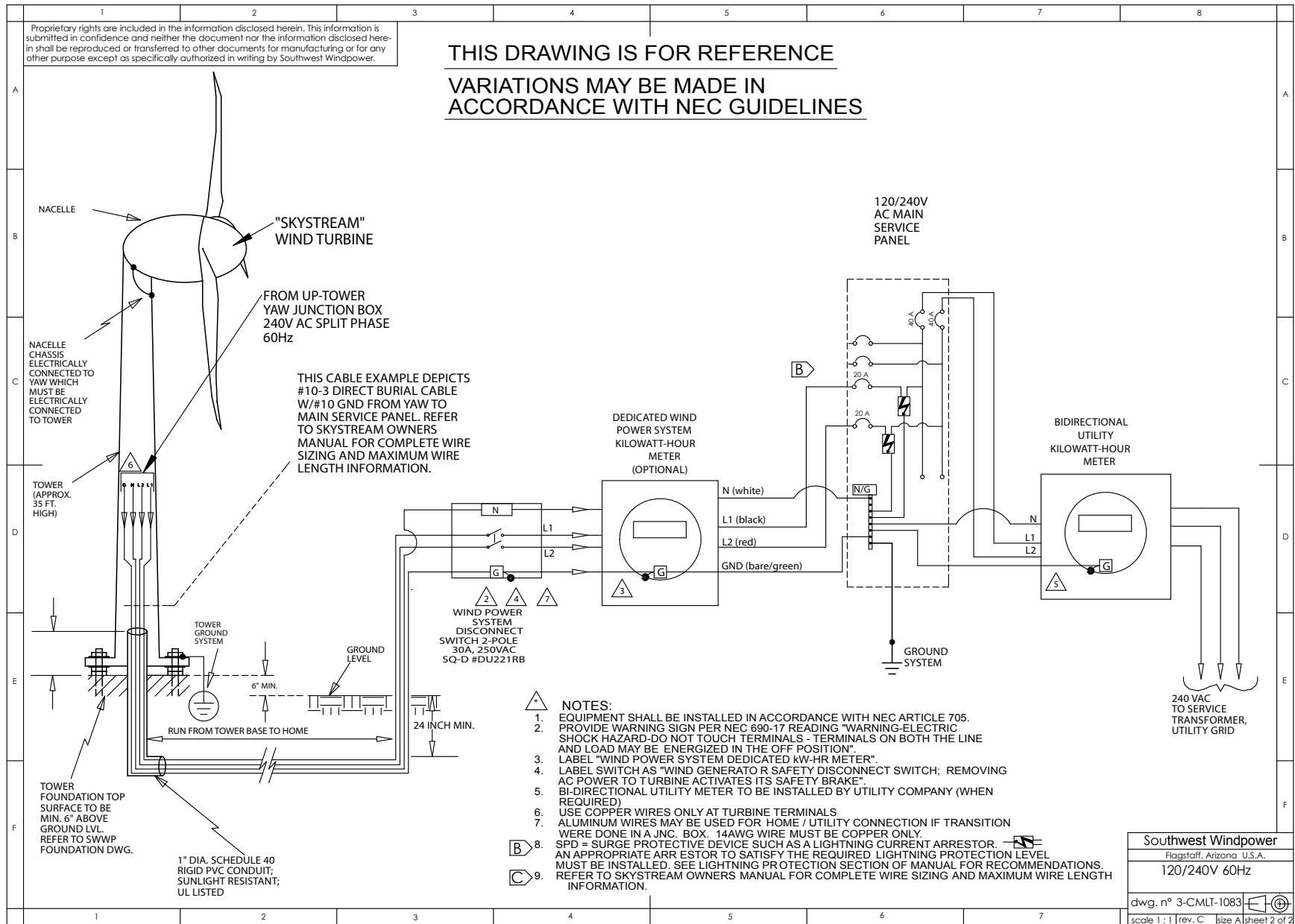

Fig. 3. Grid Connection Option C: 120/208 V, 60 Hz, 3 Phase, Junction Box at Tower Base

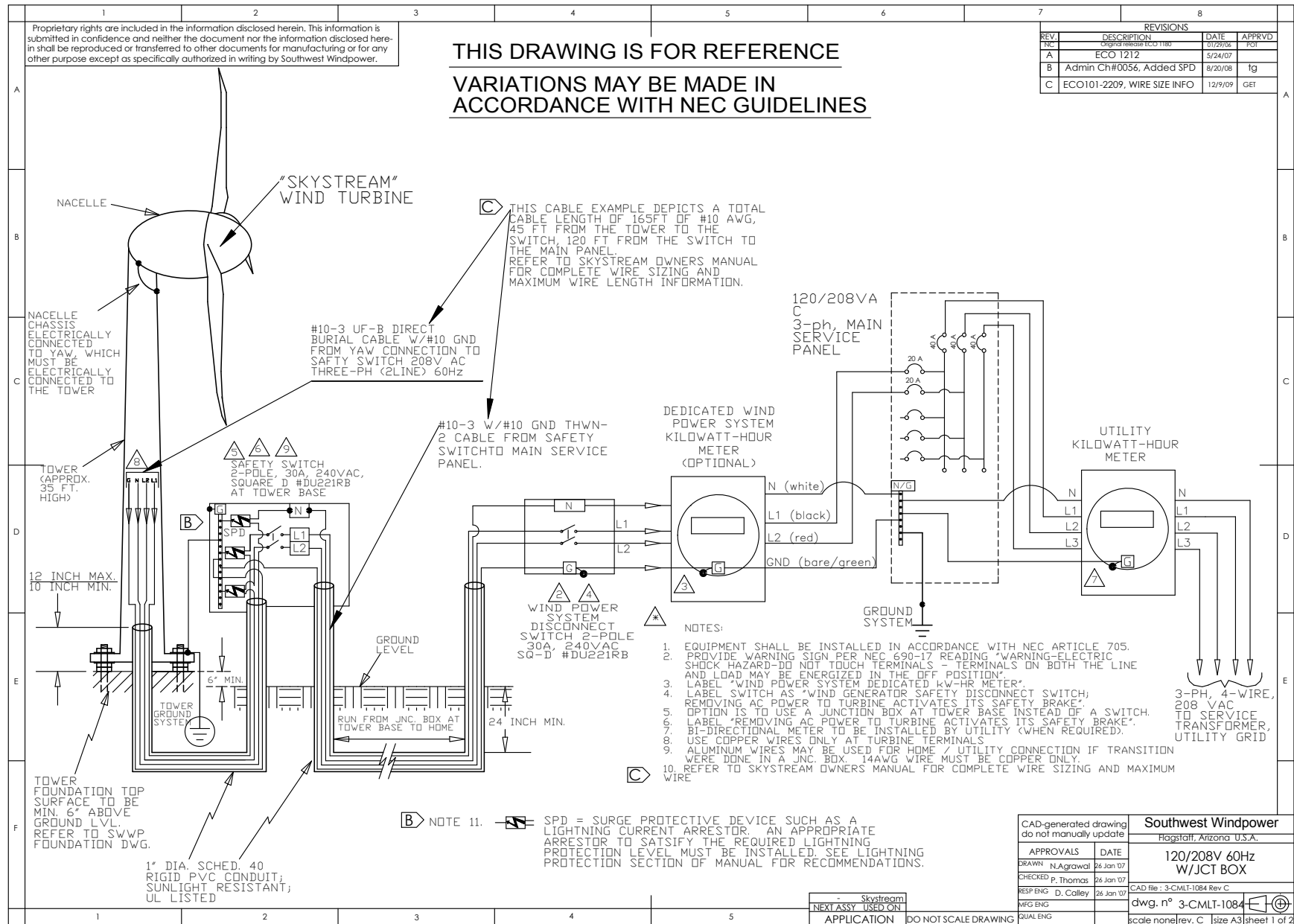

Fig. 4. Grid Connection Option D: 120/208 V, 60 Hz, 3 Phase, Without Junction Box at Tower Base

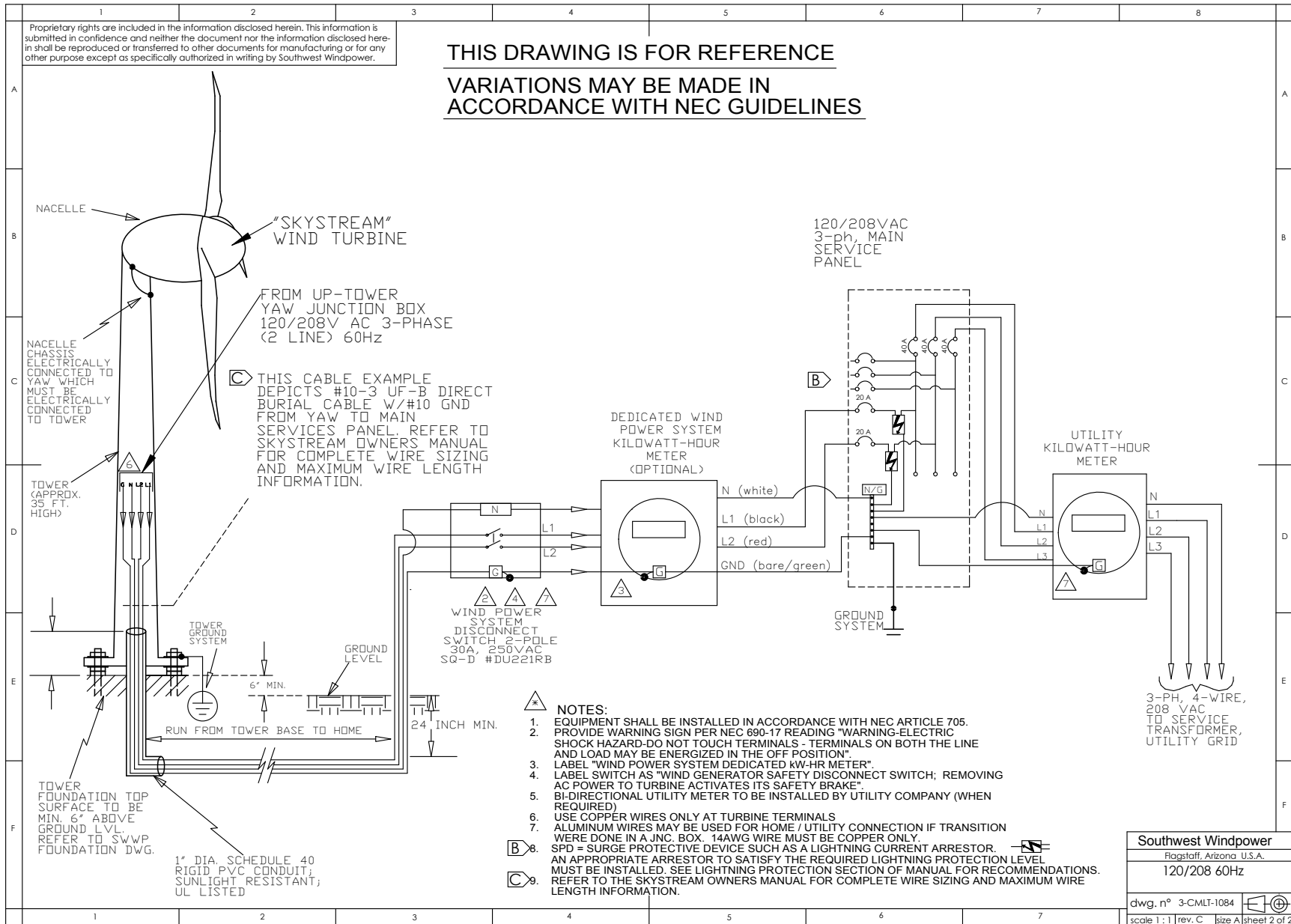
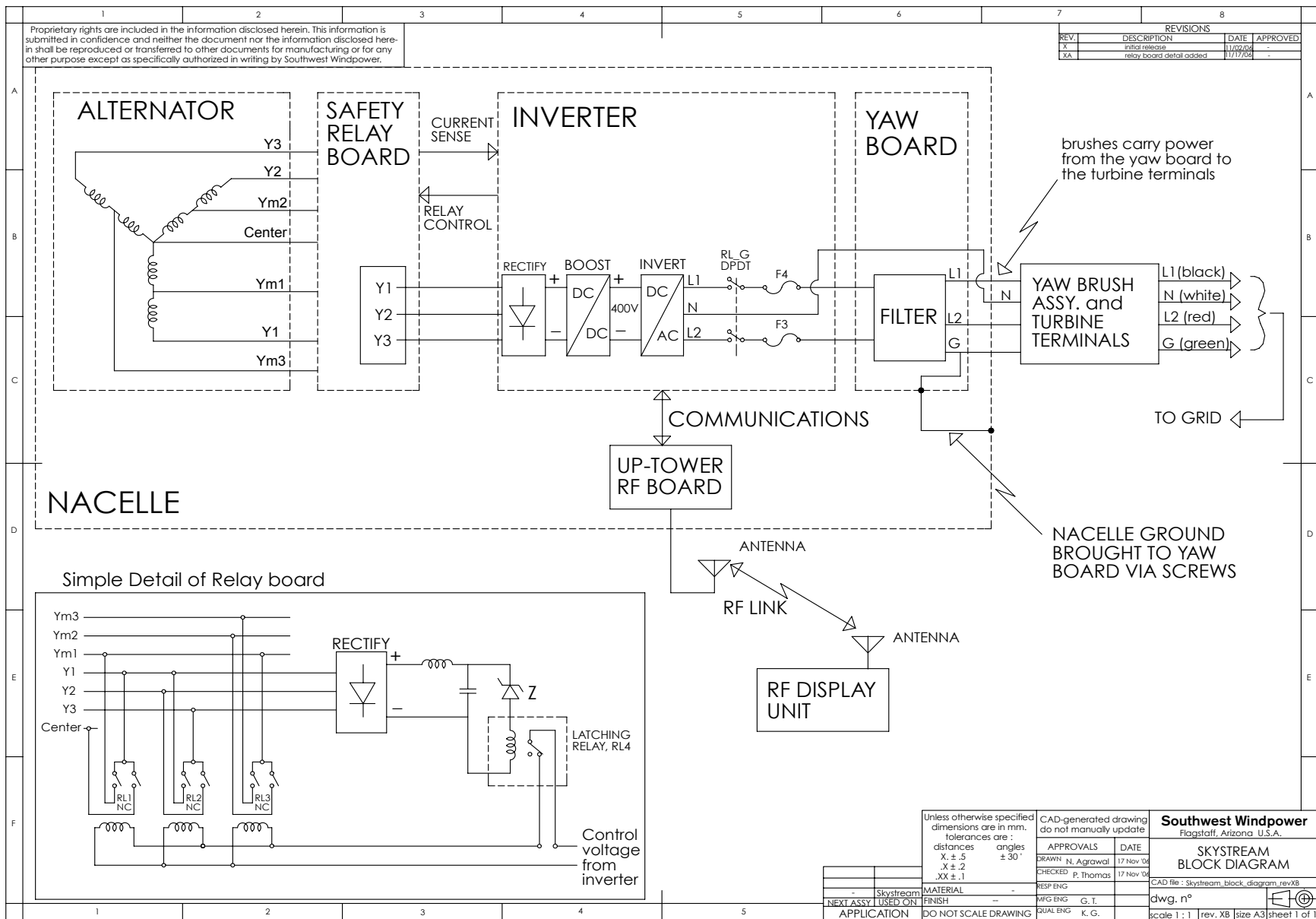
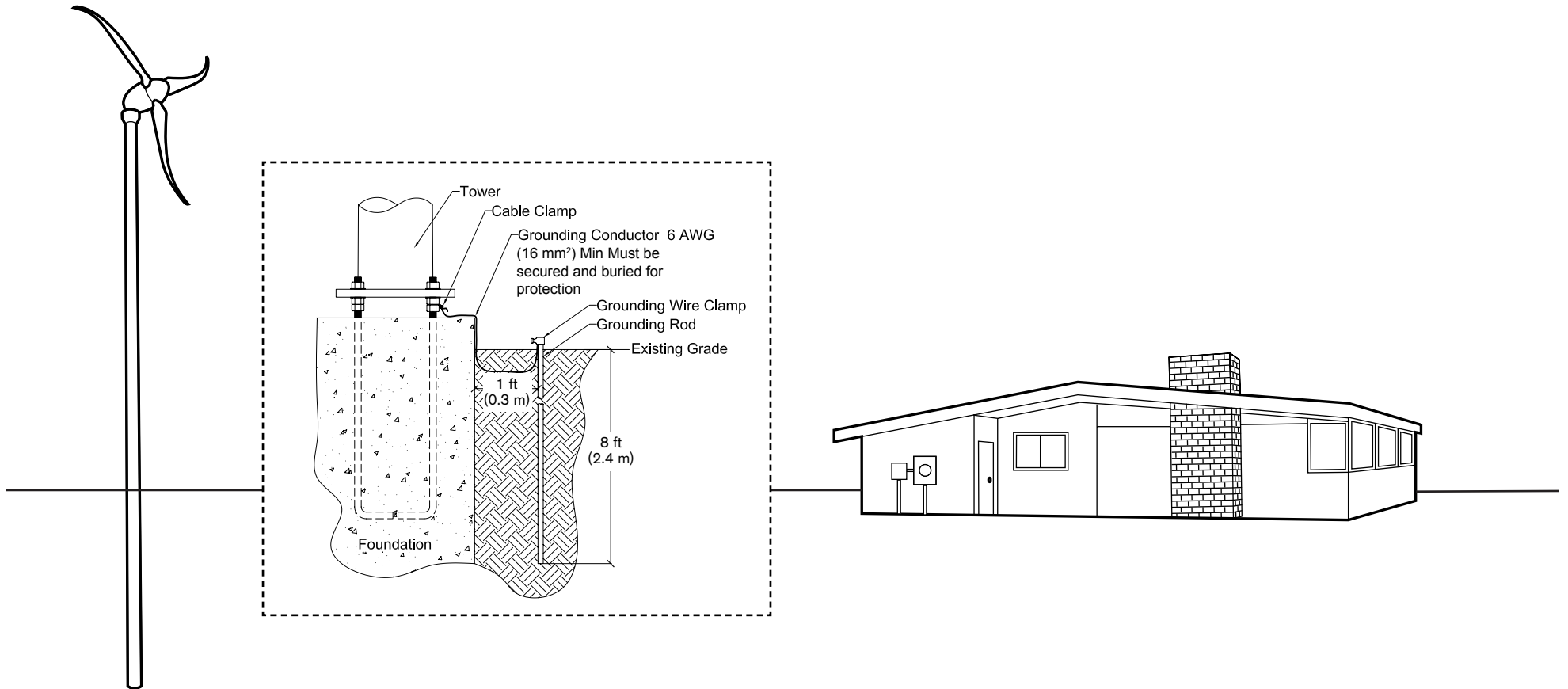

Fig. 5. Skystream Block Diagram



SKYSTREAM 3.7[®]

APPENDIX B: TOWER GROUNDING



Skystream 3.7[®] Owner's Manual

Appendix B: Tower Grounding

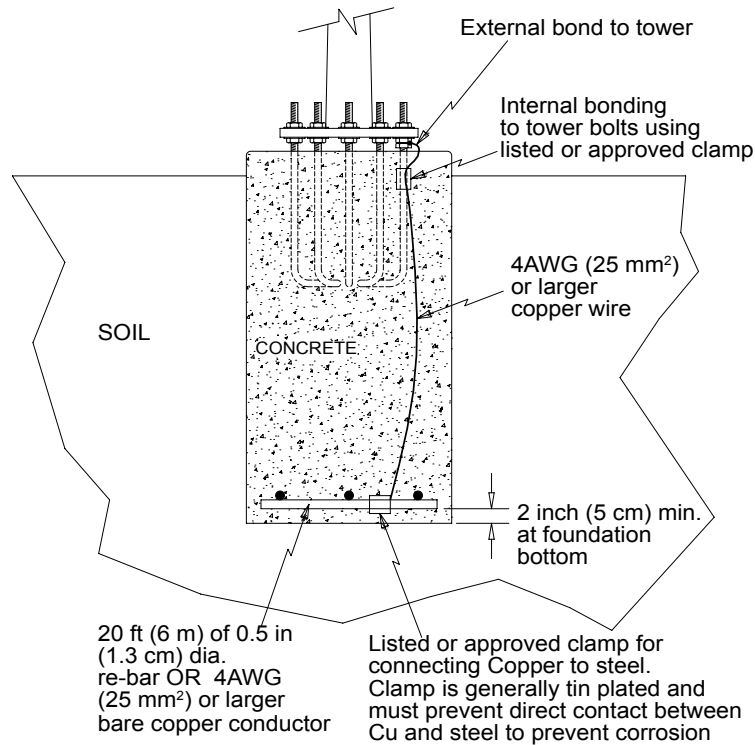

Important Safety Instructions _____ 3

1) INTRODUCTION _____ 4

2) **GROUNDING TECHNIQUES** _____ 4

2-1 Copper Clad Electrodes Driven Into Soil _____ 4

2-1-1 Grounding Electrode Installation _____ 5

2-1-2 Electrode Resistance to Ground _____ 5

2-1-3 Grounding Electrode Conductor: Material, Size, Bonding to Electrode & Bonding to Tower _____ 6

2-1-4 Conductor Size _____ 6

2-1-5 Bonding the Grounding Electrode Conductor to the Earth Electrode _____ 6

2-1-6 Bonding the Grounding Electrode Conductor to the Tower _____ 6

2-1-6-1 Using a Tower Bolt/Nut Assembly _____ 6

2-1-6-2 Using a Grounding Lug at Tower Base _____ 7

2-1-6-3 Using Exothermic Welding _____ 7

2-2 Electrodes Encased in the Concrete - Tower Foundation _____ 7

2-3 Bolting Grounding Lug to Tower Base _____ 8

IMPORTANT SAFETY INSTRUCTIONS

READ THESE INSTRUCTIONS IN THEIR ENTIRETY BEFORE INSTALLING.



Professional installation
highly recommended

- 1) **SAVE THESE INSTRUCTIONS.** This manual contains important instructions for grounding your Skystream tower.
- 2) Read these instructions in their entirety before beginning.
- 3) Do not start installation unless all required equipment and tools are on site.

In this guide



TIP: Helpful information to ease the installation



Professional installation
highly recommended



Warning: Risk of injury or death - proceed with extreme caution

One - Introduction

Even though the wind turbine is grounded at the service panel, it must also be grounded at the tower base. Grounding the tower at its base may prevent electrical shocks, voltage surges and static charge build up. Proper tower grounding may also limit or minimize damage due to lightning strikes.

This document provides recommendations for grounding small wind turbine systems with rated line currents of less than 200A to achieve compliance with the 2005 USA National Electrical Code (NEC) as well as IEC (International Electrotechnical Commission) standard 60364-5-54 Selection and Erection of Electrical Equipment – Earthing Arrangements, Protective Conductors and Protective Bonding Conductors.

The grounding information contained in this document is provided as a reference. Please refer to the aforementioned NEC and IEC standards for complete detailed information. Local building codes and electrical standards may differ from the information presented here and have precedence over this document.

Two - Grounding Techniques

There are several tower grounding techniques compliant with NEC and IEC standards; this document presents two of the most common approaches:

- **Copper clad electrodes driven into the soil**
- **Electrodes encased in the concrete of the tower foundation**

2-1 Copper Clad Electrodes Driven Into the Soil

The figure 1 depicts a typical tower grounded using an electrode driven into the soil.

The tower may be grounded using a copper-clad electrode(s) of appropriate diameter and length. See the section entitled "Electrode Resistance to Ground" to determine the dimensions of the rod. The electrode shall be

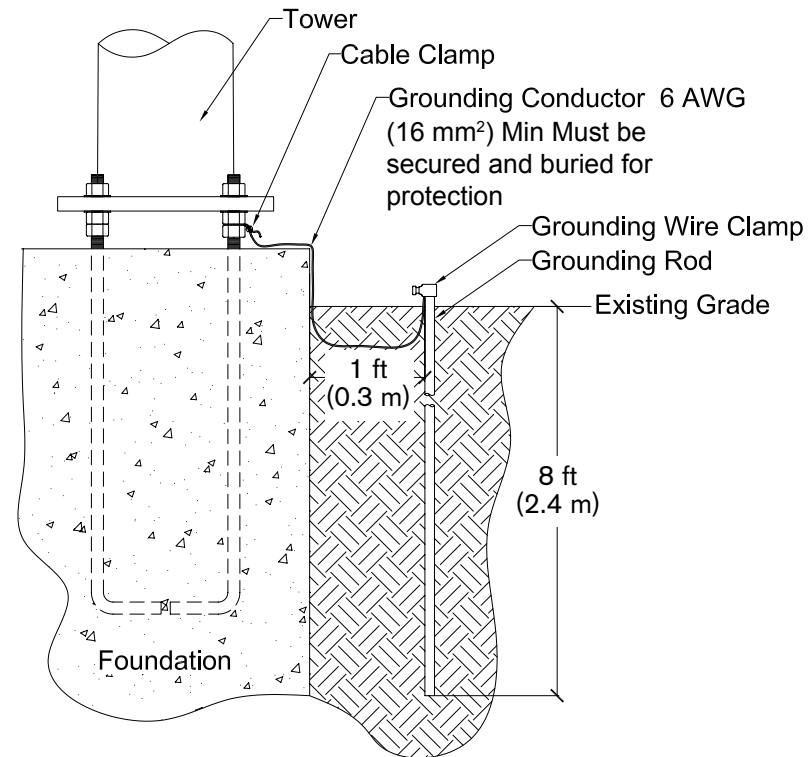

Fig. 1 Electrode driven into ground.

free from non-conductive coatings such as paint or enamel. Rod and pipe electrodes shall not be less than 2.5 m in length and shall consist of the following materials:

- a) Electrodes of pipe or conduit (hollow electrodes) shall not be smaller than metric designator 21 (trade size 3/4) and, where of iron or steel, shall have the outer surface galvanized or otherwise metal-coated for corrosion protection.
- b) Electrodes of rods of iron or steel shall be at least 15.87 mm in diameter. Stainless steel rods less than 16 mm in diameter, nonferrous rods, or their equivalent shall be listed* and shall not be less than 13 mm in diameter.

NEC section 250.52 and in accordance with the user's local electrical code authority.

*Be included in a list published by an organization (or marked as such) that is acceptable to the local authority having jurisdiction in the area. For example, UL/CSA listed in USA/Canada.

2-1-1 Grounding Electrode Installation

The following information is excerpted from the 2005 NEC article 250.53 (G). Refer to code for additional detailed information.

The electrode shall be installed such that at least 2.44 m of length is in contact with the soil. It shall be driven into undisturbed soil within 0.3 m of the tower foundation. It shall be driven to a depth of not less than 2.44 m except that, where rock bottom is encountered, the electrode shall be driven at an oblique angle not to exceed 45 degrees from the vertical or, where rock bottom is encountered at an angle up to 45 degrees, the electrode shall be permitted to be buried in a trench that is at least 750 mm deep. The upper end of the electrode shall be flush with or below ground level unless the aboveground end and grounding electrode conductor are protected against physical damage as specified below (quoted from 2005 NEC article 250.10):

- a) In installations where they are not likely to be damaged
- b) Where enclosed in metal, wood, or equivalent protective covering

2-1-2 Electrode Resistance to Ground

The resistance to earth of a single ground rod can be calculated using Dwight's equation:

$R = [r/(2\pi L)] \times [\ln(4L/R) - 1]$, where r is the soil resistivity, L is the length of the rod buried inside the earth and R = radius of the rod; \ln stands for the natural logarithm.

For calculating the resistance of the rod to ground, one must know the value of soil resistivity. This may be found in the local electrical code or building inspector's office/municipal office or by an actual soil resistivity test.

The resistance of a rod electrode to ground may be lowered by increasing the rod diameter, increasing the buried length of the rod or by treatment of the soil to reduce its resistivity.

If the single chosen electrode does not have a resistance to ground of 10 ohm or less, it shall be augmented by additional electrodes as necessary. The overall resistance of multiple rods to ground would roughly equal the resistance of a single rod to ground divided by the number of rods. Where multiple such electrodes are installed to meet the above requirement, they shall not be less than 1.8 m apart. The multiple rods must be bonded together using the grounding electrode conductor.

2-1-3 Grounding Electrode Conductor: Material, Size, Bonding to Electrode and Bonding to Tower

Material (Ref. 2005 NEC articles 250.62, 250.96(A)).

The grounding electrode conductor shall be of copper, aluminium, or copper-clad aluminium. The material selected shall be resistant to any corrosive condition existing at the installation or shall be suitably protected against corrosion. The conductor shall be solid or stranded, insulated, covered or bare. Any non-conductive paint, enamel, or similar coating shall be removed at threads, contact points, and contact surfaces or be connected by means of fittings designed so as to make such removal unnecessary.

Note: Many local electrical standards do not permit the use of aluminium or copper-clad aluminium conductors and strictly require the use of copper conductors.

2-1-4 Conductor Size

(Ref. 2005 NEC article 250.66(A)):

Where the grounding electrode conductor is connected to rod, pipe or plate electrodes, that portion of the conductor that is the sole connection to the grounding electrode shall be a minimum of 6AWG copper wire or 4AWG aluminium wire.

2-1-5 Bonding the Grounding Electrode Conductor to the Earth Electrode

(Ref. 2005 NEC article 250.70):

The grounding or bonding conductor shall be connected to the grounding electrode by exothermic welding, listed lugs, listed pressure connectors, listed clamps, or other listed means. Connections depending on solder shall not be used. Ground clamps shall be listed (approved) for the materials of the grounding electrode and the grounding electrode conductor and, where used on pipe, rod or other buried electrodes, shall also be listed for direct soil burial.

2-1-6 Bonding the Grounding Electrode Conductor to the Tower

The grounding conductor may be connected to the tower by any one of the following means:

2-1-6-1 Using a Tower Bolt/Nut Assembly

- a) Pre-assemble the extra nut (supplied in the tower bolt kit) on one of the tower bolts containing nuts "A" or "B" as shown in fig. 2C of Skystream Foundation and Tower Installation Manual. Move the extra nut towards the bottom of the bolt so that it does not interfere with the nut to go on top of it.
- b) Assemble the nut and washer on top as explained in the Installation Manual. Generously apply a listed "joint compound" to the sandwiching surfaces of the two nuts as well as to the tower bolt in question. The joint compound must be of the type to prevent corrosion between copper and galvanized steel.
- c) Take one end of the grounding conductor and loop it once around the tower bolt containing the extra nut, between the upper and lower nut. Generously apply joint compound to the grounding conductor and cable clamp in the area of attachment. Secure the conductor with a cable clamp around the loop so that it just clears the tower nuts and keeps the loop snug around the tower bolt (see fig. 3). The cable clamp is required so that the ground wire does not slip out from between the nuts when the lower nut is tightened.
- d) Ensure that surfaces of the lower and upper nuts facing each other are free of dirt and have very clean surfaces. If necessary, wash and clean these surfaces. This is essential for a good electrical connection between the ground conductor and the tower. Tighten the lower nut towards the upper nut applying sufficient torque (50 lb-ft or 68 N·m minimum) to securely clamp the grounding wire (see fig. 3).
- e) Erect the tower and level it as required by adjusting any or all of the tower nuts. You may have to loosen the ground wire nut during this adjustment. After adjusting the tower level, re-tighten the lower nut to the suggested torque to make sure the ground wire is securely sandwiched and bound between the two nuts.

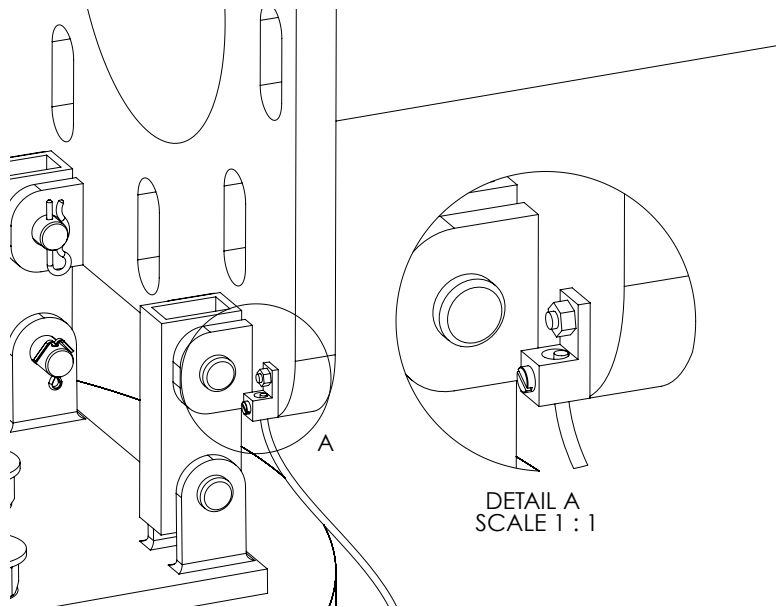

Fig. 2 Attaching the grounding wire to the tower base.

2-1-6-2 Using a Grounding Lug at Tower Base

Bond the grounding conductor to the tower base flange through a ground terminal lug attached to the tower base as shown in figure 2. Use a 1/4-20 x 44.5 mm long stainless steel bolt through a hole in the tower base and a Nyloc stainless steel nut to fasten the ground lug to the underside of the tower base. The ground lug must be UL listed and must be a type that accommodates up to 1/0 AWG wire minimum.

2-1-6-3 Using Exothermic Welding

Bond the grounding conductor to the tower base flange by exothermic welding of the conductor to the base flange. Make exothermic welds strictly in accordance with the weld manufacturer's written recommendations.

Electrode conductor routing and placement / installation:

Ensure that the grounding conductor has no sharp bends in it. This is important to keep its inductance low. The grounding conductor may be buried or contained in a conduit as explained in 2005 NEC article 250.64.

2-2 Electrodes encased in the concrete of the tower foundation (reference 2005 NEC article 250.52(A)(3))

A grounding electrode may also be encased in the concrete of the tower foundation. The electrode is located at the bottom of the foundation and connects to the tower mounting "J" bolts and to the tower base by means of a grounding conductor.

Because the grounding electrode will be encased in concrete it should be inspected and approved prior to pouring the foundation to avoid conflicts with local construction inspectors.

Two types of electrodes, their locations and their connection to the electrode grounding conductor are described below:

- a) The electrode must be at least 6.0 m of one or more (electrically connected by steel tie wires) bare or zinc galvanized steel or other electrically conductive coated steel reinforcing bars or rods of not less than 13 mm in diameter, located near the bottom of the concrete foundation that is in direct contact with the earth. The electrode must be encased by at least 50 mm of concrete as shown in figure 4. The reinforcing bars, if bare, must not be rusted at the time of installation to prevent bad electrical connection between bars and with the grounding electrode conductor. The reinforcing bars must be electrically connected to the anchor bolts either using the steel tie wires or using the grounding electrode conductor. The grounding electrode conductor must not be smaller than 4AWG copper and must be electrically bonded to the bottom reinforcing bars using listed/approved means that is suitable for concrete encasement. Sufficient extra length of the conductor must be available to bring it out of the foundation top and at least 46 cm above the foundation top. It should then be bonded to the tower as described in section 2-1-6 of this document.

b) The electrode must be least 6.0 m of bare copper conductor not smaller than 4AWG. The copper conductor, which may be in the form of a coil, must lie at the bottom of the foundation with either a 5 cm thick (maximum) tamped fill of earth covering the grounding coil or covered in concrete a maximum of 5 cm above the soil at the bottom of the foundation. Sufficient extra length must be present in the copper conductor to bring it at least 46 cm above the foundation top where it should be bonded to the tower as described in section 2-1-6 of this document. On its way up, the copper conductor must also be bonded to the tower anchor bolts using a clamp listed or approved means that is suitable for concrete encasement and also suitable for connecting copper to steel. This listed clamp is generally tin plated and must be of the type to prevent direct contact between copper and steel to prevent corrosion.

2-3 Bolting Grounding Lug to Tower Base

An alternate method of attaching the electrode grounding conductor to the tower is to drill a hole through the base and utilize a commercially available lug as depicted in figure 2. To connect the grounding conductor to the tower base using this approach drill a 6 mm hole through the tower base. After joining the grounding conductor to the listed lug according to the lug manufacturer's instructions, bolt the lug to the tower base with a stainless steel bolt and self-locking nut. The listed lug is generally tin plated and prevents corrosion between the galvanized steel tower and the copper conductor.

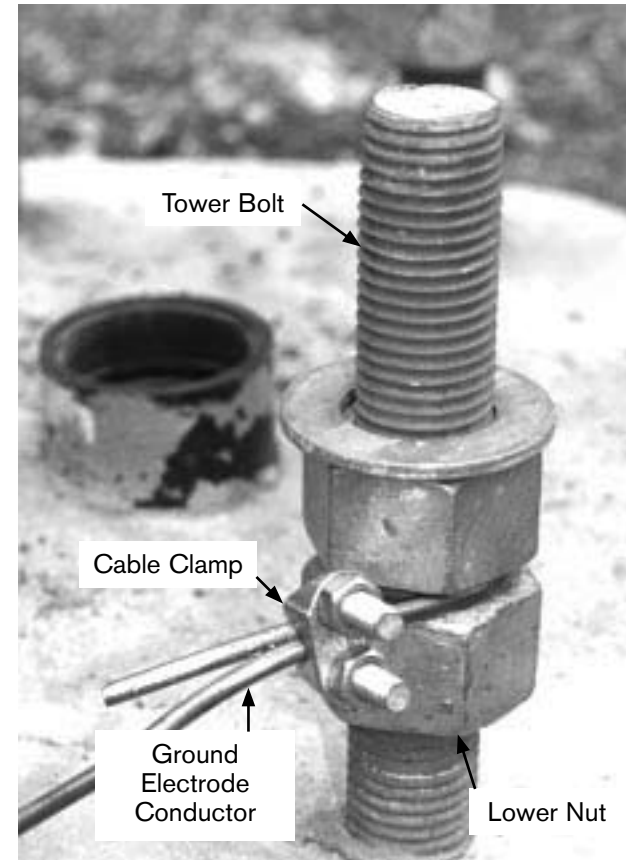

Fig. 3 Tower foundation bolt.

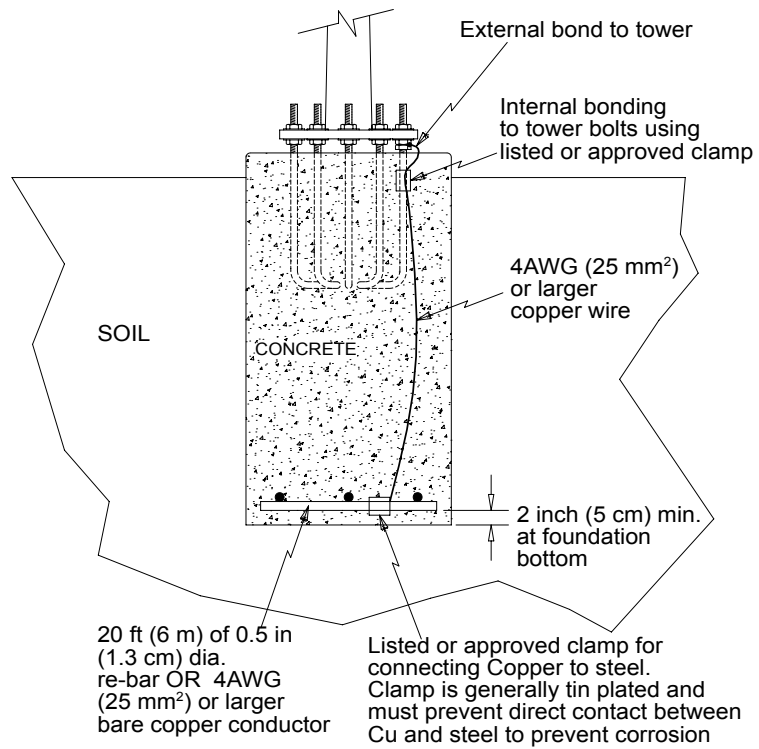
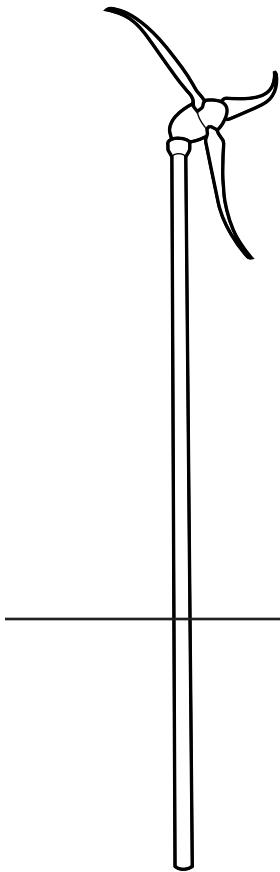

Fig. 4 Concrete encased electrode.

SKYSTREAM 3.7®

APPENDIX C: LIGHTNING PROTECTION



53	0.765	0.976	-0.176	0.882	0.988	-3.705	0.0
76	0.882	0.988	0.412	0.941	0.994	-1.353	0.0
6	0.922	0.992	0.608	0.961	0.966	-0.568	0.0
2	0.941	0.994	0.706	0.971	0.997	-0.176	0.0
9	0.953	0.995	0.765	0.976	0.998	0.059	0.0
8	0.961	0.996	0.804	0.980	0.998	0.216	0.0
4	0.966	0.997	0.832	0.983	0.998	0.328	0.0
6	0.971	0.997	0.853	0.985	0.999	0.412	0.0
9	0.974	0.997	0.869	0.987	0.999	0.477	0.0
5	0.976	0.998	0.882	0.988	0.999	0.529	0.0
6	0.979	0.998	0.893	0.989	0.999	0.572	0.0
4	0.980	0.998	0.902	0.990	0.999	0.608	0.0
9	0.982	0.998	0.910	0.991	0.999	0.638	0.0
2	0.983	0.998	0.916	0.992	0.999	0.664	0.0
3	0.984	0.998	0.922	0.992	0.999	0.686	0.0
3	0.985	0.999	0.926	0.993	0.999	0.706	0.0

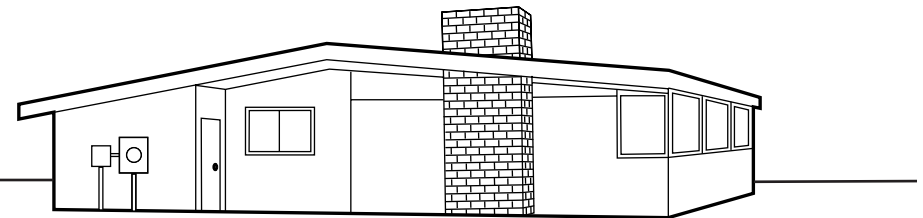

Skystream 3.7[®] Owner's Manual

Appendix D: Lightning Protection

Important Safety Instructions _____	3
Introduction _____	4
Location of Lightning Current Arrestors _____	4
Selecting Appropriate Lightning Protection System _____	4
Determine Tower Height _____	5
Determine Flash Density _____	5
Table 1: Lightning Protection Efficiency for 33 ft Tower _____	5
Determine Topography _____	6
Permitted Annual Number of Critical Event (Nc) _____	6
Lightning Protection System Efficiency _____	6
Table 2: Lightning Protection Efficiency for 45 ft Tower _____	6
Table 3: Lightning Protection Efficiency for 60 ft Tower _____	7
Table 4: Lightning Protection Efficiency for 70 ft Tower _____	8
Lightning Protection Level _____	8
Select Model & Number of Lightning Current Arrestor(s) _____	9

IMPORTANT SAFETY INSTRUCTIONS

READ THESE INSTRUCTIONS IN THEIR ENTIRETY BEFORE INSTALLING.



Professional installation
highly recommended

- 1) **SAVE THESE INSTRUCTIONS.** This manual contains important instructions for grounding your Skystream monopole tower.
- 2) Read these instructions in their entirety before beginning.
- 3) Do not start installation unless all required equipment and tools are on site.

In this guide



IMPORTANT:
Please take note



Professional installation
highly recommended



Warning: Risk of injury or death - proceed with extreme caution

Introduction

The Skystream 3.7 turbine is designed to withstand over voltages and surge currents (6kV, 3kA, 8/20 μ s) caused by indirect lightning strikes or switching operations according to the Standard for Interconnecting Distributed Resources with Electric Power Systems (IEEE 1547). For this protection to be effective, it is necessary to ensure that over voltages at the connection terminals will not be higher than the above values of the surge test.

To provide this over voltage protection against direct lightning strikes; a Type 1 lightning current arrester, that reduces over voltages to a level below 6 kV but is capable of discharging very high currents, much larger than those handled by surge protective devices present inside Skystream is required. Type 1 lightning arrestors have been tested to withstand over voltages and surge currents representing a direct lightning strike, described by a 10/350 μ s type waveform.

Since the Skystream is intended to be installed worldwide in all kinds of environments, some more vulnerable to lightning than others, the Lightning Protection System's (LPS) efficiency (E), and hence the current rating of the Type 1 Lightning Current Arrester, may be selected to meet local requirements.

Location of the Lightning Current Arrester(s):

For Skystream installations with metallic tubular towers where the tower and turbine installation, earthing or grounding has been performed as per the Owner's manual, analysis has shown that the best protection is provided when the Type 1 arrester is placed at or near the base of the tower.

Selecting the Appropriate Lightning Protection System

An appropriate Lightning Protection System is selected after determining the Lightning Protection System Efficiency and thus the Lightning Protection Level (Level 1 through 4). To determine these, one needs to further determine the following parameters.

The parameters include:

- The tower height
- Flash Density (Ng)
- Topography of Installation site
- Permitted Annual Number of Critical Events (Nc)

Once these parameters are defined a specific Model of Lightning Current Arrester may be determined.



IMPORTANT: More than one arrester may be required depending upon the level of protection required.

The Lightning Protection System (LPS) "Protection Level" is based on the number of lightning "critical events" allowed per year and the lightning flash density in the target area. A "critical event" is described as the failure of the lightning protection system (LPS).

If there is risk of damage to the wind turbine or associated power networks and devices due to a critical event (or injury or loss of life), then the protection system must be designed to keep the Permitted Annual Number of Critical Events, Nc, under an acceptable value. This is the acceptable number of annual lightning strikes that will cause one damage incident.



IMPORTANT: Nc is generally set by the local jurisdiction or by the owner or installer of the system and needs to meet local safety laws.

Determine Tower Height

Determine your tower height and select **Table 1, 2, 3 or 4** corresponding to a 33, 45, 60 or 70 ft. tower (10, 14, 18 or 21 m). **Tables 1, 2, 3 and 4** are utilized to calculate the Lightning Protection System Efficiencies corresponding to the tower height.

 **IMPORTANT:** If the tower height falls in between the heights for which the tables are available in this manual, select the table for the next higher tower height.

Determine the Flash Density (Ng)

Determine the Annual Average Ground Flash Density (per km²), Ng, in your area. This number may be obtained from information published by National organizations, meteorological organizations and is generally available on the internet. For example, Global Atmospheric Inc. (also known as Vaisala-GAI Inc.), publishes lightning strike data. Be careful to obtain most recent data available, as there may be considerable variability in data from one year to next, especially with the present climate change.

An example website is given below:

http://www.crh.noaa.gov/pub/?n=/ltg/flash_density_maps_index.php

Ng may range anywhere between 1 and 70. Select the row corresponding to the Ng in your area. For non-integer values, the next higher integral number must be chosen.

 **Warning:** Be careful to obtain most recent data available, as there may be considerable variability in data from one year to next, especially with the present climate change.

Table 1 - Lightning Protection Efficiency for 33 ft (10m) Towers

Ng	Isolated Flat Land			Hill or Knoll			Non-Isolated Flat Land		
	E = Lightning protection system efficiency			E = Lightning protection system efficiency			E = Lightning protection system efficiency		
	Nc = 1/100	Nc = 1/1000	Nc = 1/10000	Nc = 1/100	Nc = 1/1000	Nc = 1/10000	Nc = 1/100	Nc = 1/1000	Nc = 1/10000
	0.01	0.001	0.0001	0.01	0.001	0.0001	0.01	0.001	0.0001
1	-1.353	0.765	0.976	-0.176	0.882	0.988	-3.705	0.529	0.953
2	-0.176	0.882	0.988	0.412	0.941	0.994	-1.353	0.765	0.976
3	0.216	0.922	0.992	0.608	0.961	0.966	-0.568	0.843	0.984
4	0.412	0.941	0.994	0.706	0.971	0.997	-0.176	0.882	0.988
5	0.529	0.953	0.995	0.765	0.976	0.998	0.059	0.906	0.991
6	0.608	0.961	0.996	0.804	0.980	0.998	0.216	0.922	0.992
7	0.664	0.966	0.997	0.832	0.983	0.998	0.328	0.933	0.993
8	0.706	0.971	0.997	0.853	0.985	0.999	0.412	0.941	0.994
9	0.739	0.974	0.997	0.869	0.987	0.999	0.477	0.948	0.995
10	0.765	0.976	0.998	0.882	0.988	0.999	0.529	0.953	0.995
11	0.786	0.979	0.998	0.893	0.989	0.999	0.572	0.957	0.996
12	0.804	0.980	0.998	0.902	0.990	0.999	0.608	0.961	0.996
13	0.819	0.982	0.998	0.910	0.991	0.999	0.638	0.964	0.216
14	0.832	0.983	0.998	0.916	0.992	0.999	0.664	0.966	0.997
15	0.843	0.984	0.998	0.922	0.992	0.999	0.686	0.969	0.997
16	0.853	0.985	0.999	0.926	0.993	0.999	0.706	0.971	0.997
17	0.862	0.986	0.999	0.931	0.993	0.999	0.723	0.972	0.997
18	0.869	0.987	0.999	0.935	0.993	0.999	0.739	0.974	0.997
19	0.876	0.988	0.999	0.938	0.994	0.999	0.752	0.975	0.998
20	0.882	0.988	0.999	0.941	0.994	0.999	0.765	0.976	0.998
30	0.922	0.992	0.999	0.961	0.996	1.000	0.843	0.984	0.998
40	0.941	0.994	0.999	0.971	0.997	1.000	0.882	0.988	0.999
50	0.953	0.995	1.000	0.976	0.998	1.000	0.906	0.991	0.999
60	0.961	0.996	1.000	0.980	0.998	1.000	0.922	0.992	0.999
70	0.966	0.967	1.000	0.983	0.998	1.000	0.933	0.993	0.999

Determine the Topography

Inspect the topography of the area in which the turbine is installed and select the one category that best describes the topography:

- **Isolated Flat Land:** No structures present within a circle of radius three times the height of the turbine (with the turbine at the center of the circle)
- **Knoll / Hill**
- **Un-isolated Flat Land:** Smaller structures present within a circle of radius three times the height of turbine (with turbine at center of the circle)

Permitted Annual Number of Critical Events (Nc)

Determine Nc. Three “Annual Number of Critical Event” options are provided in the tables. The least protective option is 1 /100 (1 in 100); the most protective is 1/10000 (1 in 10,000).



Warning: If there is risk of injury or danger to human life, then maximum allowed Nc is generally 1 in 100,000 or less, depending on laws of various states or countries.

As Skystream installations on relatively short towers (like 33 ft - 70 ft / 10m - 21m) do not significantly increase risk of injury or danger to human life, the Efficiency (E) is calculated with higher values of Nc (for example, 1/1000 is larger than 1/100,000).

However, Nc must be chosen to comply with local electrical safety laws. Some authorities may require Nc = 1/100,000 for better protection. The result of choosing such a low Nc would mean that a lightning protection system with Level 1 protection will need to be installed.

Table 2 - Lightning Protection Efficiency for 45 ft (14m) Towers

Ng	Isolated Flat Land			Hill or Knoll			Non-Isolated Flat Land		
	efficiency			efficiency			efficiency		
	Nc = 1/100	Nc = 1/1000	Nc = 1/10000	Nc = 1/100	Nc = 1/1000	Nc = 1/10000	Nc = 1/100	Nc = 1/1000	Nc = 1/10000
	0.01	0.001	0.0001	0.01	0.001	0.0001	0.01	0.001	0.0001
1	-0.427	0.875	0.986	0.287	0.929	0.993	-1.853	0.715	0.971
2	0.287	0.929	0.993	0.643	0.964	0.996	-0.427	0.857	0.986
3	0.524	0.952	0.995	0.762	0.976	0.998	0.049	0.905	0.990
4	0.643	0.964	0.996	0.822	0.982	0.998	0.287	0.929	0.993
5	0.715	0.971	0.997	0.857	0.986	0.999	0.429	0.943	0.994
6	0.762	0.976	0.998	0.881	0.988	0.999	0.524	0.952	0.995
7	0.796	0.980	0.998	0.898	0.990	0.999	0.592	0.959	0.996
8	0.822	0.982	0.998	0.911	0.991	0.999	0.643	0.964	0.996
9	0.841	0.984	0.998	0.921	0.992	0.999	0.683	0.968	0.997
10	0.857	0.986	0.999	0.929	0.993	0.999	0.715	0.971	0.997
11	0.870	0.987	0.999	0.935	0.994	0.999	0.741	0.974	0.997
12	0.881	0.988	0.999	0.941	0.994	0.999	0.762	0.976	0.998
13	0.890	0.989	0.999	0.945	0.995	0.999	0.781	0.978	0.998
14	0.898	0.990	0.999	0.949	0.995	0.999	0.796	0.980	0.998
15	0.905	0.990	0.999	0.952	0.995	1.000	0.810	0.981	0.998
16	0.911	0.991	0.999	0.955	0.996	1.000	0.822	0.982	0.998
17	0.916	0.992	0.999	0.958	0.996	1.000	0.832	0.983	0.998
18	0.921	0.992	0.999	0.960	0.996	1.000	0.841	0.984	0.998
19	0.925	0.992	0.999	0.962	0.996	1.000	0.752	0.985	0.998
20	0.929	0.993	0.999	0.964	0.996	1.000	0.857	0.986	0.999
30	0.952	0.995	1.000	0.976	0.998	1.000	0.905	0.990	0.999
40	0.964	0.996	1.000	0.982	0.998	1.000	0.929	0.993	0.999
50	0.971	0.997	1.000	0.986	0.999	1.000	0.943	0.994	0.999
60	0.976	0.998	1.000	0.988	0.999	1.000	0.952	0.995	1.000
70	0.980	0.998	1.000	0.990	0.999	1.000	0.959	0.996	1.000

Table 3 - Lightning Protection Efficiency for 60 ft (18m) Towers

	Isolated Flat Land			Hill or Knoll			Non-Isolated Flat Land		
Ng	efficiency			efficiency			efficiency		
	Nc = 1/100	Nc = 1/1000	Nc = 1/10000	Nc = 1/100	Nc = 1/1000	Nc = 1/10000	Nc = 1/100	Nc = 1/1000	Nc = 1/10000
	0.01	0.001	0.0001	0.01	0.001	0.0001	0.01	0.001	0.0001
1	0.143	0.914	0.991	0.572	0.957	0.996	-0.714	0.829	0.983
2	0.572	0.957	0.996	0.786	0.979	0.998	0.143	0.914	0.991
3	0.714	0.971	0.997	0.857	0.986	0.999	0.429	0.943	0.994
4	0.786	0.979	0.998	0.893	0.989	0.999	0.572	0.957	0.996
5	0.829	0.983	0.998	0.914	0.991	0.999	0.657	0.966	0.997
6	0.857	0.986	0.999	0.929	0.993	0.999	0.714	0.971	0.997
7	0.878	0.988	0.999	0.939	0.994	0.999	0.755	0.976	0.998
8	0.893	0.989	0.999	0.946	0.995	0.999	0.786	0.979	0.998
9	0.905	0.990	0.999	0.952	0.995	1.000	0.810	0.981	0.998
10	0.914	0.991	0.999	0.957	0.996	1.000	0.829	0.983	0.998
11	0.922	0.992	0.999	0.961	0.996	1.000	0.844	0.984	0.998
12	0.929	0.993	0.999	0.964	0.996	1.000	0.857	0.986	0.999
13	0.934	0.993	0.999	0.967	0.997	1.000	0.868	0.987	0.999
14	0.939	0.994	0.999	0.969	0.997	1.000	0.878	0.988	0.999
15	0.943	0.994	0.999	0.971	0.997	1.000	0.886	0.989	0.999
16	0.946	0.995	0.999	0.973	0.997	1.000	0.893	0.989	0.999
17	0.950	0.995	0.999	0.975	0.997	1.000	0.899	0.990	0.999
18	0.952	0.995	1.000	0.976	0.998	1.000	0.905	0.990	0.999
19	0.955	0.995	1.000	0.977	0.998	1.000	0.910	0.991	0.999
20	0.957	0.996	1.000	0.979	0.998	1.000	0.914	0.991	0.999
30	0.971	0.997	1.000	0.986	0.999	1.000	0.943	0.994	0.999
40	0.979	0.998	1.000	0.989	0.999	1.000	0.957	0.996	1.000
50	0.983	0.998	1.000	0.991	0.999	1.000	0.966	0.997	1.000
60	0.986	0.999	1.000	0.993	0.999	1.000	0.971	0.997	1.000
70	0.988	0.999	1.000	0.994	0.999	1.000	0.976	0.998	1.000

The Lightning Protection System Efficiency (E)

Using the appropriate Efficiency Table for the tower height, select the sub-column corresponding to the installation topography – Isolated Flat Land, Hill or Knoll, or Non-isolated Flat Land.

The data cell at the intersection of Flash Density value (Ng) row and the Permitted Number of Critical Events (Nc) column will indicate The Lightning System Efficiency “E”. If E is negative, no lightning protection is required.

IMPORTANT: If “E” is negative, no lightning protection is required.

Table 4 - Lightning Protection Efficiency for 70 ft (21m) Towers

	Isolated Flat Land			Hill or Knoll			Non-Isolated Flat Land		
Ng	efficiency			efficiency			efficiency		
	Nc = 1/100	Nc = 1/1000	Nc = 1/10000	Nc = 1/100	Nc = 1/1000	Nc = 1/10000	Nc = 1/100	Nc = 1/1000	Nc = 1/10000
	0.01	0.001	0.0001	0.01	0.001	0.0001	0.01	0.001	0.0001
1	0.352	0.935	0.994	0.676	0.968	0.997	-0.296	0.870	0.987
2	0.676	0.968	0.997	0.838	0.984	0.998	0.352	0.935	0.994
3	0.784	0.978	0.998	0.892	0.989	0.999	0.568	0.957	0.996
4	0.838	0.984	0.998	0.919	0.992	0.999	0.676	0.968	0.997
5	0.870	0.987	0.999	0.935	0.994	0.999	0.741	0.974	0.997
6	0.892	0.989	0.999	0.946	0.995	0.999	0.784	0.978	0.998
7	0.907	0.991	0.999	0.954	0.995	1.000	0.815	0.981	0.998
8	0.919	0.992	0.999	0.960	0.996	1.000	0.838	0.984	0.998
9	0.928	0.993	0.999	0.964	0.996	1.000	0.856	0.986	0.999
10	0.935	0.994	0.999	0.968	0.997	1.000	0.870	0.987	0.999
11	0.941	0.994	0.999	0.971	0.997	1.000	0.882	0.988	0.999
12	0.946	0.995	0.999	0.973	0.997	1.000	0.892	0.989	0.999
13	0.950	0.995	1.000	0.975	0.998	1.000	0.900	0.990	0.999
14	0.954	0.995	1.000	0.977	0.998	1.000	0.907	0.991	0.999
15	0.957	0.996	1.000	0.978	0.998	1.000	0.914	0.991	0.999
16	0.960	0.996	1.000	0.980	0.998	1.000	0.919	0.992	0.999
17	0.962	0.996	1.000	0.981	0.998	1.000	0.924	0.992	0.999
18	0.964	0.996	1.000	0.982	0.998	1.000	0.928	0.993	0.999
19	0.966	0.997	1.000	0.983	0.998	1.000	0.932	0.993	0.999
20	0.968	0.997	1.000	0.984	0.998	1.000	0.935	0.994	0.999
30	0.978	0.998	1.000	0.989	0.999	1.000	0.957	0.996	1.000
40	0.984	0.998	1.000	0.992	0.999	1.000	0.968	0.997	1.000
50	0.987	0.999	1.000	0.994	0.999	1.000	0.974	0.997	1.000
60	0.989	0.999	1.000	0.995	0.999	1.000	0.978	0.998	1.000
70	0.991	0.999	1.000	0.995	1.000	1.000	0.981	0.998	1.000

The Lightning Protection Level

Refer to **Table 5**, the “Lightning Protection Level” and using the Efficiency (E) determine the Lightning Protection Level (LPL) and corresponding peak lightning current discharge capability.

Lightning Protection Level 1 provides highest level of protection and Lightning Protection Level 4, the lowest level of protection.

Table 5 - Lightning Protection Level

Efficiency	Lightning Protection Level
$E > 0.980$	Lightning Protection Level 1 with additional measures
$0.95 < E \leq 0.98$	Lightning Protection Level 1
$0.90 < E \leq 0.95$	Lightning Protection Level 2
$0.80 < E \leq 0.90$	Lightning Protection Level 3
$0 < E \leq 0.80$	Lightning Protection Level 4

Select Model and Number of Lightning Current Arrestor(s)

Select the appropriate model and quantity of the Type 1 lightning current arrestor(s) required from **Table 6**. The selection method is described below:

The lightning arrestor peak current rating is the peak current carrying capability of each pole or contact of the arrestor. It is generally assumed that the total current the surge arrestor will end up carrying (cumulatively, in all its phases), is about 50% of the total lightning discharge current. Say, if there is 100kA of peak discharge current due to lightning, 50kA will flow through ground, and the other 50kA will be divided between L1, L2 and N, thus requiring the surge arrestor to be rated for ~16kA per phase.

This concept of lightning current division is described in **Reference (3)** listed at the end of the lightning protection description.

Lightning and surge protection is intended to be placed between each phase (hot line) conductor and ground, and possibly between ground and neutral, if the distance between the neutral and ground bond is significant. Therefore the voltage rating of the SPD is to be based on phase (hot line) to neutral values (since neutral and ground are connected at the main service panel, and hence normally at the same potential).

Following table shows example lightning current arrestor recommendations (single pole versions with spark-gap technology).

Note: Lightning Current Arrestors from DEHN Inc. have been cited here, however, comparable arrestors from other companies may be utilized.

Table 6 - Type 1 Lightning Current Arrestor Recommendations: One Pole Versions (spark-gap technology)

Efficiency	Lightning Protection Level (LPL)	Peak Lightning Current Discharge/ Sinking Capability	120/240V split 1-ph and 120/208V system (L1, L2, N, G)	230V, 1-ph system (L, N, G)
$E > 0.980$	LPL with added measures	200kA	DEHNbloc Maxi 150 (DB M 1 150), AT LEAST one each L1-G, L2-G, N-G	DB M 1 255, AT LEAST one each between L-G, N-G
$0.95 < E \leq 0.98$	LPL 1	200kA	DB M 1 150, one each between L1-G, L2-G, N-G	DB M 1 255, one each between L-G, N-G
$0.90 < E \leq 0.95$	LPL 2	150kA	DB M 1 150, one each between L1-G, L2-G (N-G optional)	DB M 1 255, one each between L-G, N-G
$0.80 < E \leq 0.90$	LPL 3	100kA	DB M 1 150, one each between L1-G, L2-G	DB M 1 255, one between L-G (N-G optional)
$0 < E \leq 0.80$	LPL 4	100kA	DB M 1 150, one each between L1-G, L2-G	DB M 1 255, one between L-G (N-G optional)

Notes: Above specified arrestors are manufactured by DEHN Inc.

Part number & price for above models are:

DEHNbloc Maxi 150 (DB M 1 150), part#, 961 110, limp = 35kA, list price \$268.00 as of May 2008

DEHNbloc Maxi 255 (DB M 1 255), part#, 961 120, limp = 50kA, list price \$336.00 as of May 2008

The arrestors shown above are manufactured by DEHN Inc.

and may be obtained in the USA by ordering from:

DEHN Inc., 106 SW Peacock Blvd. # 207

Port St. Lucie, FL 34986 - Tel: (772) 340-7006; Fax: (772) 343-0703

References:

- 1) IEC 61400-24, IEC 61400-2.
- 2) DEHN Lightning Protection Guide
- 3) Characteristics of Direct Strike Lightning Events and Risk Assessment, Dr. -Ing Peter Hasse, Managing Director, DEHN, PEG 2001 Meeting, Las Vegas, March 27-29, 2001.
- 4) National Electric Code, 2005 Handbook, National Fire Protection Association (USA).

SKYSTREAM 3.7®

APPENDIX D CERTIFICATION/COMPLIANCE

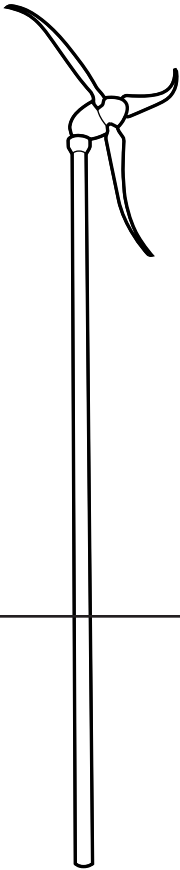

Skystream 3.7, Land, 230V, 50Hz, 1Ph (Item# 1-S\$
Skystream 3.7, Marine, 230V, 50Hz, 1Ph (Item# 1-

I declare that Skystream 3.7 small wind turbine meets the essential requirements by design and construction as follows:

Comply with the Machinery Directive 98/37/EC.
Comply with the small wind turbine design standard IEC 61400

Comply with Directive 2005/88/EC for noise limits and labeling
we comply to all safety aspects of the Low Voltage Directive
is certified in USA to comprehensive safety standards UL174

Comply to the R&TTE directive 99/5/EC and will have undergone testing by Underwriters Laboratories to document conformity

Comply to the EMC directive 2004/108/EC by August 1, 2011
100% compliant to RoHS directive 2002/95/EC and will fully comply

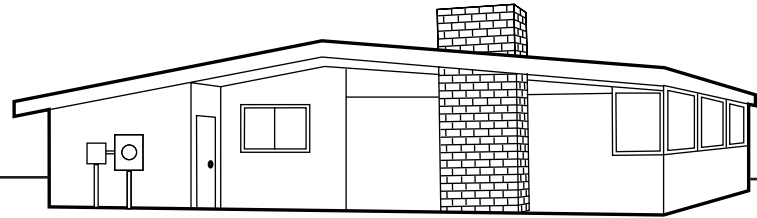

MADE IN THE USA

© 2012 Southwest Windpower, Inc.
All Rights Reserved

Certificate of Compliance

Certificate Number **20090219E300731**
Report Reference **E300731**, Issued: **2006-10-17**
Issue Date **2009 February 19**

Page 1 of 2



Southwest Windpower Inc

1801 W Rte 66
Flagstaff, AZ 86001
United States

This is to certify that representative samples of

Skystream Inverter

Component inverter for use with Skystream wind turbine, Utility Interactive Ready

Have been investigated by Underwriters Laboratories in accordance with the Standard(s) indicated on this Certificate.



Standard(s) for Safety:

UL 1741, Standard for Safety for Inverters, Converters, Controllers and Interconnection System Equipment for Use With Distributed Energy Resources, 1st Ed.; IEEE 1547-2003; CAN/CSA-C22.2 No.107.1-01, 3rd Ed.

Additional Information:

See Addendum

Only those products bearing the UL Recognized Component Marks for the U.S. and Canada should be considered as being covered by UL's Recognition and Follow-Up Service and meeting the appropriate U.S. and Canadian requirements.

The UL Recognized Component Mark for the U.S. generally consists of the manufacturer's identification and catalog number, model number or other product designation as specified under "Marking" for the particular Recognition as published in the appropriate UL Directory. As a supplementary means of identifying products that have been produced under UL's Component Recognition Program, UL's Recognized Component Mark  may be used in conjunction with the required Recognized Marks. The Recognized Component Mark is required when specified in the UL Directory preceding the recognitions or under "Markings" for the individual recognitions. The UL Recognized Component Mark for Canada consists of the UL Recognized Mark for Canada:  and the manufacturer's identification and catalog number, model number or other product designation as specified under "Marking" for the particular Recognition as published in the appropriate UL Directory.

Look for the UL Recognized Component Mark on the product

Issued by: **Chris Storbeck**

Reviewed by: **Tim Zgonena**

Chris Storbeck, Sr. Project Engineer

Tim Zgonena, Primary Designated Engineer

Underwriters Laboratories Inc.

Underwriters Laboratories Inc.

Any information and documentation involving UL Mark services are provided on behalf of Underwriters Laboratories Inc. (UL) or any authorized licensee of UL. For questions in The United States of America you may call 1-877-UL-HELP.

Certificate of Compliance

Certificate Number **20090219E300731**
Report Reference **E300731**, Issued: **2006-10-17**
Issue Date **2009 February 19**

Page 2 of 2



Addendum - Skystream Inverter

Inverter Output configuration: 120/240V, L-N-L,
Operating voltage range Vac: 212-264; or
Output Configuration: 120/208V, L-N-L,
Operating voltage range Vac: 183-229;
Normal output frequency Hz: 60.0;
Operating frequency range Hz: 59.3-60.5;
Rated output current Aac: 10.0;
Rated continuous output power kW@25 °C: 2.3;
Rated continuous output power kW@50°C: 1.5;
Max. peak output kW: 2.4;
Surge Category B

Alternate Firmware Combinations approved since Jan. 28, 2008:

Inverter Master Application Code:	Inverter Slave Application Code:
Revision: Rev 1.11.10	Revision: Rev 1.03
Revision: Rev 2.00.0	Revision: Rev 1.03
Revision: Rev 2.02.0	Revision: Rev 1.03

Representative samples of the SkyStream Inverter as specified on this certificate were evaluated and tested according to all current UL 1741 requirements. All Testing was performed on representative samples of the Wind Turbine system including tests to certify the Nacelle as a suitable enclosure. Unit has been tested and meets all requirements for Utility Interactive operation in accordance with:

- UL 1741, Standard for Safety for Inverters, Converters, Controllers and Interconnection System Equipment for Use With Distributed Energy Resources, 1st Ed., Revised: November 7, 2005
- IEEE 1547-2003 Standard for Interconnecting Distributed Resources with Electric Power Systems;
- IEEE 1547.1-2005 Standard Conformance Test Procedures for Equipment Interconnecting Distributed Resources with Electric Power Systems, dated: June 2003
- CAN/CSA-C22.2 No.107.1-01, 3rd Ed., General Use Power Supplies, dated: September 2001

Issued by: **Chris Storbeck**

Chris Storbeck, Sr. Project Engineer

Underwriters Laboratories Inc.

Any information and documentation involving UL Mark services are provided on behalf of Underwriters Laboratories Inc. (UL) or any authorized licensee of UL.
For questions in The United States of America you may call 1-877-UL-HELPS.

Reviewed by: **Tim Zgonena**

Tim Zgonena, Primary Designated Engineer

Underwriters Laboratories Inc.

Declaration of Conformity SKYSTREAM 3.7



Product: Skystream 3.7

Type: Skystream 3.7, Land, 230V, 50Hz, 1Ph (Item# 1-SSL-11-230)
Skystream 3.7, Marine, 230V, 50Hz, 1Ph (Item# 1-SSM-11-230)

We hereby declare that Skystream 3.7 small wind turbine meets the essential European Union requirements by design and construction as follows:

The product complies with the following Directives:

Machinery Directive 98/37/EC	RoHS Directive 2002/95/EC
Low Voltage Directive 2006/95/EC	R&TTE directive 99/5/EC*
EMC Directive 89/336/EEC and 2004/108/EC (OJ L 390/24 of 2004-12-31) as amended by 92/31/EEC, 93/68/EEC and Directive 91/263/EEC [TTE/SES]**	

* Certified by UltraTech EMC Labs Inc. for Maxstream Inc.

** Certified by Underwriters Laboratories Inc. (EMC Division).

The following standards are harmonized with the Machinery Directive. They were applied to the wind turbine and the product was found in compliance with them:

EN 954-1	EN ISO 12100-1:2003
EN 1050:1996	EN ISO 12100-2:2003

The following standards are harmonized with the Low Voltage Directive. They were applied to the wind turbine and the product was found in compliance with them:

EN 60204 -1:2006
EN 60529:1991 and Amendment A1:2000 to EN 60529:1991
EN 61400-2:2006 (Small Wind turbine design Standard)

The product also complies with Power Quality characteristics per EN 61400-21:2002.

Based on above conformance, above models are being CE-marked for export to Europe.

Remark:

The above CE compliance will be invalidated if:

- The machine is modified in any way without the explicit written consent of Southwest Windpower.
- The machine is used or connected in a manner or configuration that Southwest Windpower does not regard as its intended application.

Dated, May 22, 2008



David Calley

(President and Chief Technology Officer, Southwest Windpower)

Southwest Windpower
1801 West Rt. 66, Suite 100, Flagstaff, AZ 86001, USA, Phone: +1 928-779-9463
www.windenergy.com



Southwest Windpower Inc.
1801 West Route 66
Flagstaff, Arizona 86001 USA
t: +1 928.779.9463
f: +1 928.779.1485

www.windenergy.com

Southwest Windpower GmbH
Mannesmannstr. 6
50996 Cologne Germany
t: +49 (0) 221 16 53 94 50